

MTS MOTION QUBIC EXTENSION SET

Instruction Manual
Bedienungsanleitung
Mode d'emploi

PARTS

[dimensions in mm / different scales]
No extra or spare parts listed!

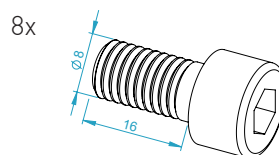
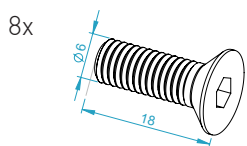
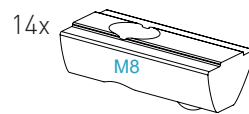
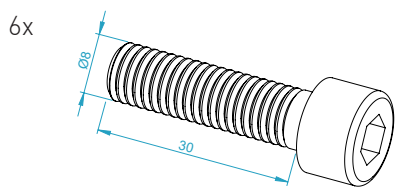
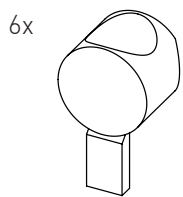
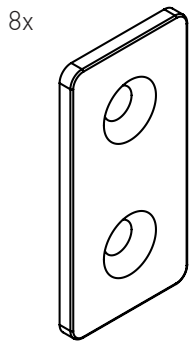
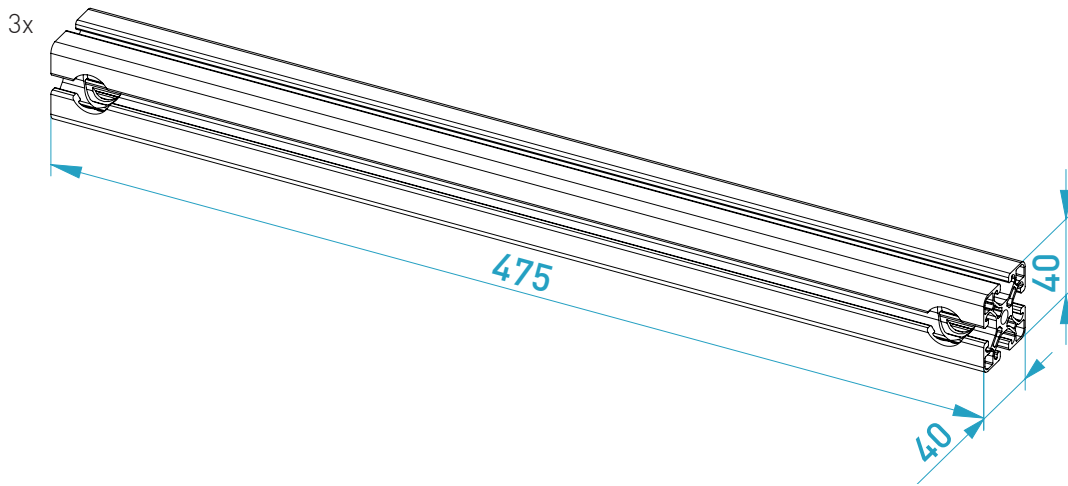

ASSEMBLY

These instructions only show how to attach the switch boxes underneath the MTS RIG.

Only the necessary material is included in the scope of delivery.
The mounting brackets for the actuators must be ordered from the manufacturer of the motion system.

For all further instructions, please read the Motion System operating instructions!

Base frame
bottom view

3 additional profiles
must be installed

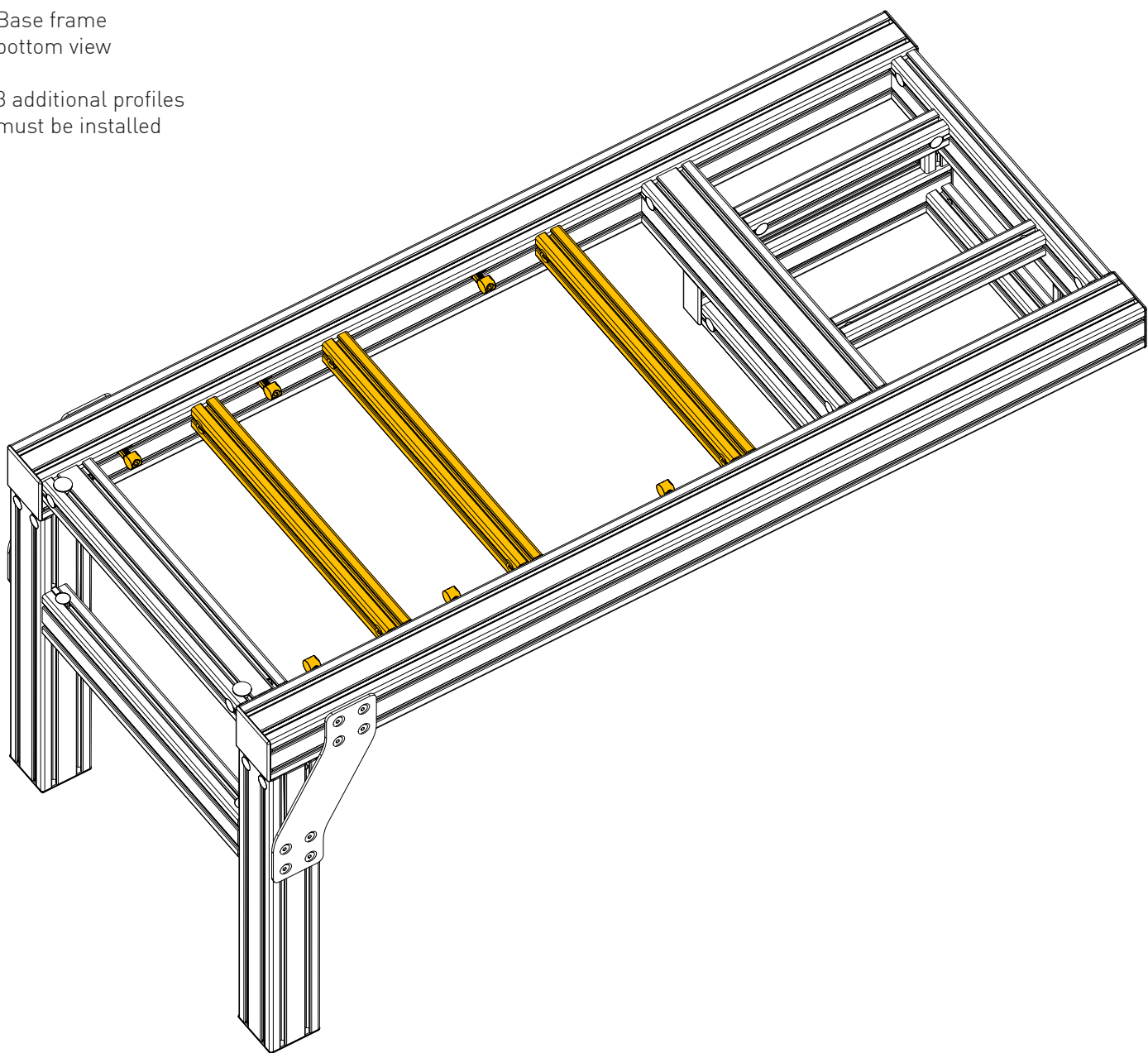

front

rear

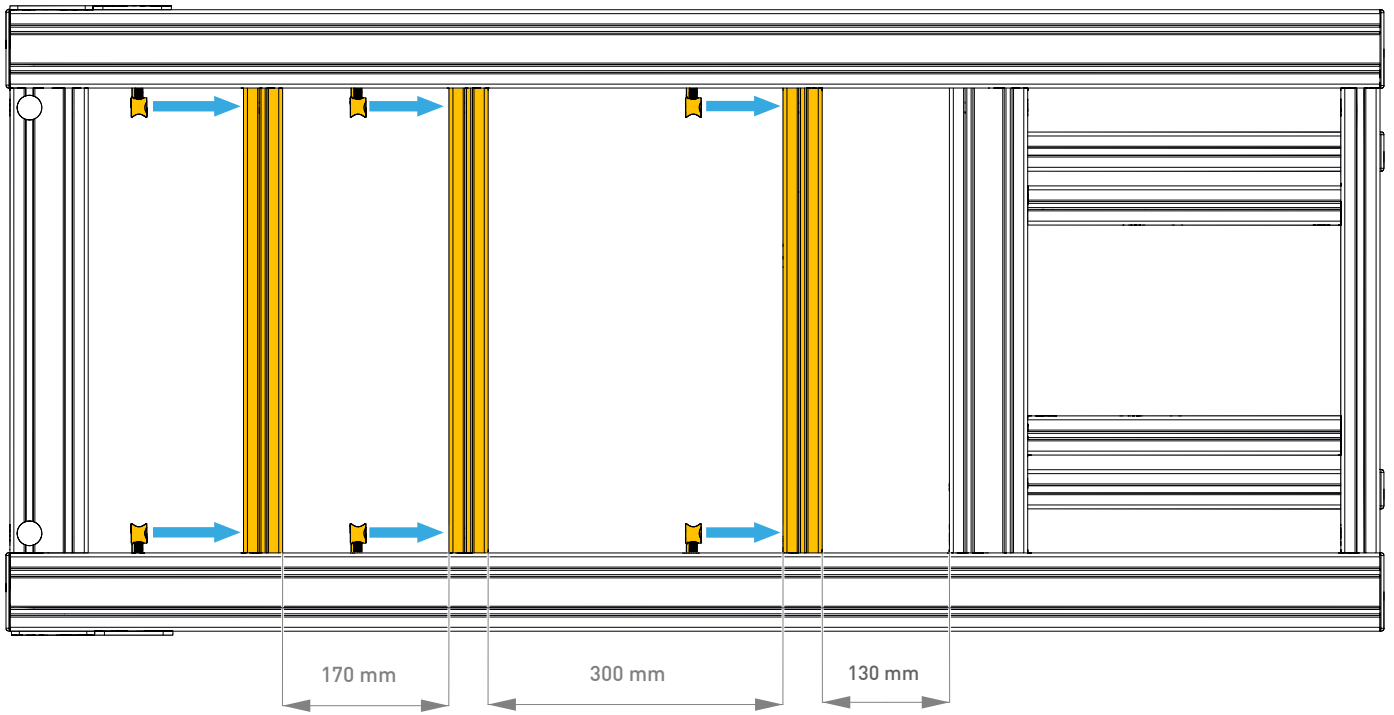

2x

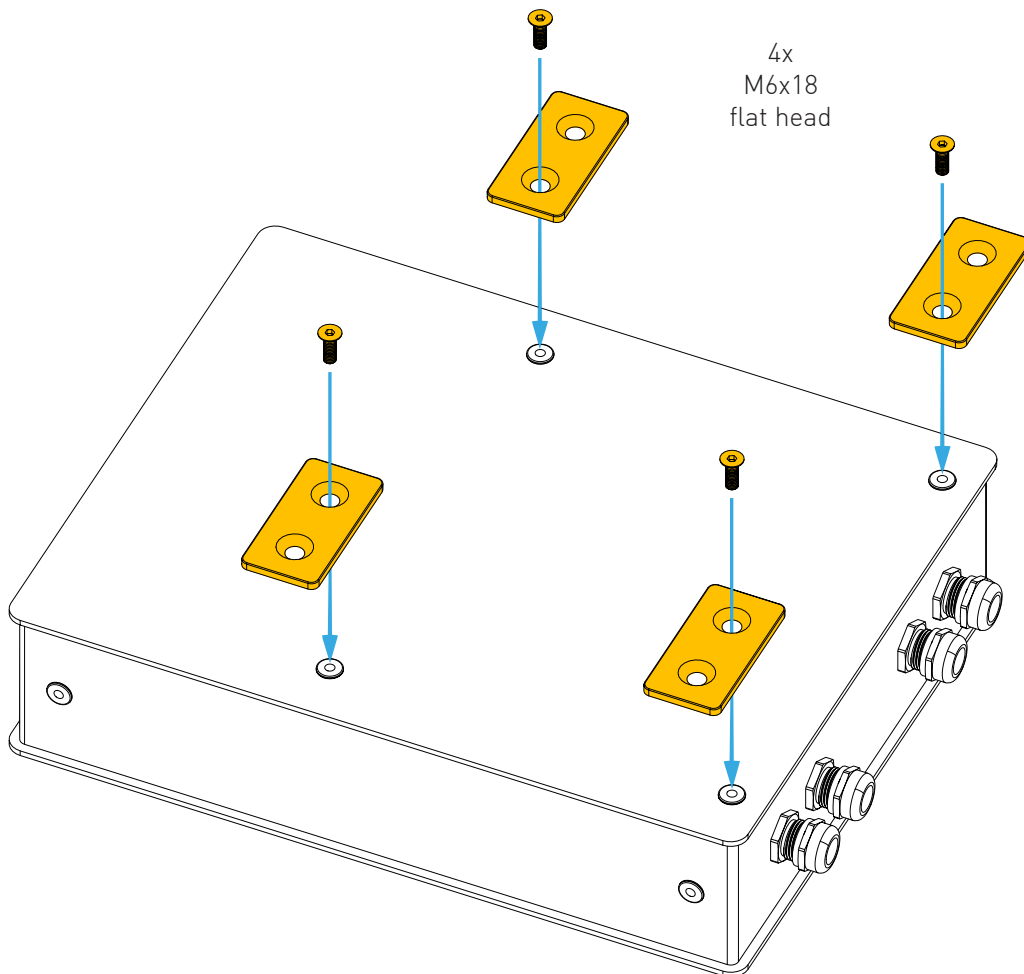

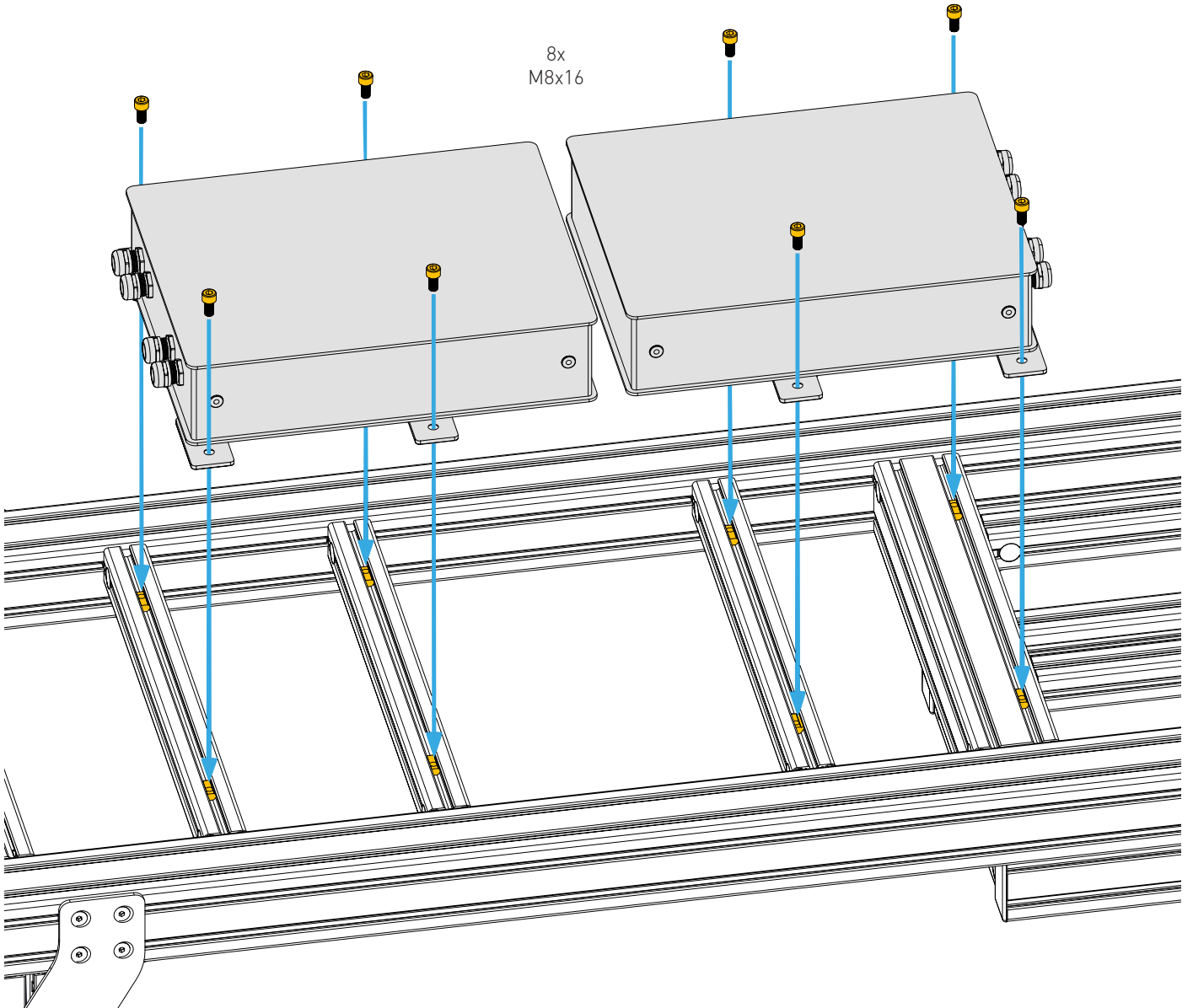
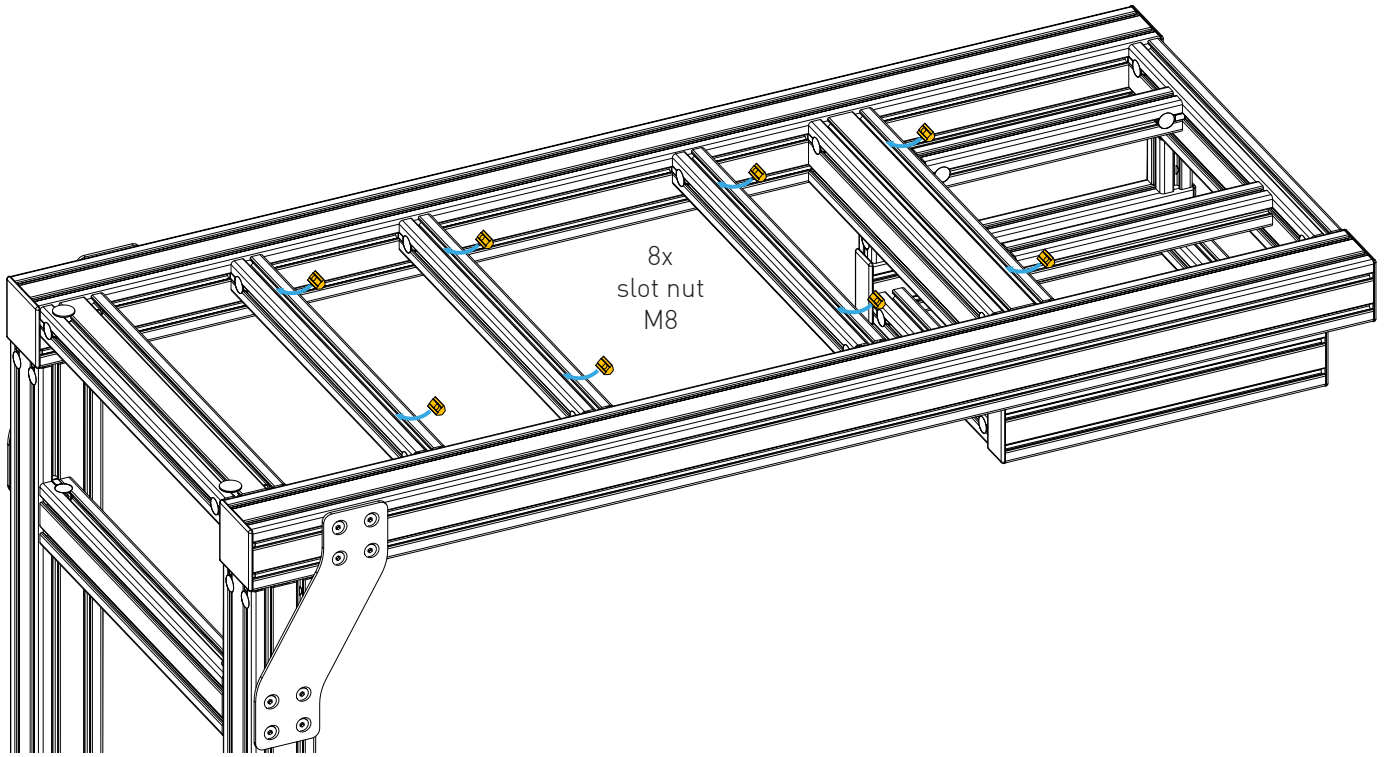

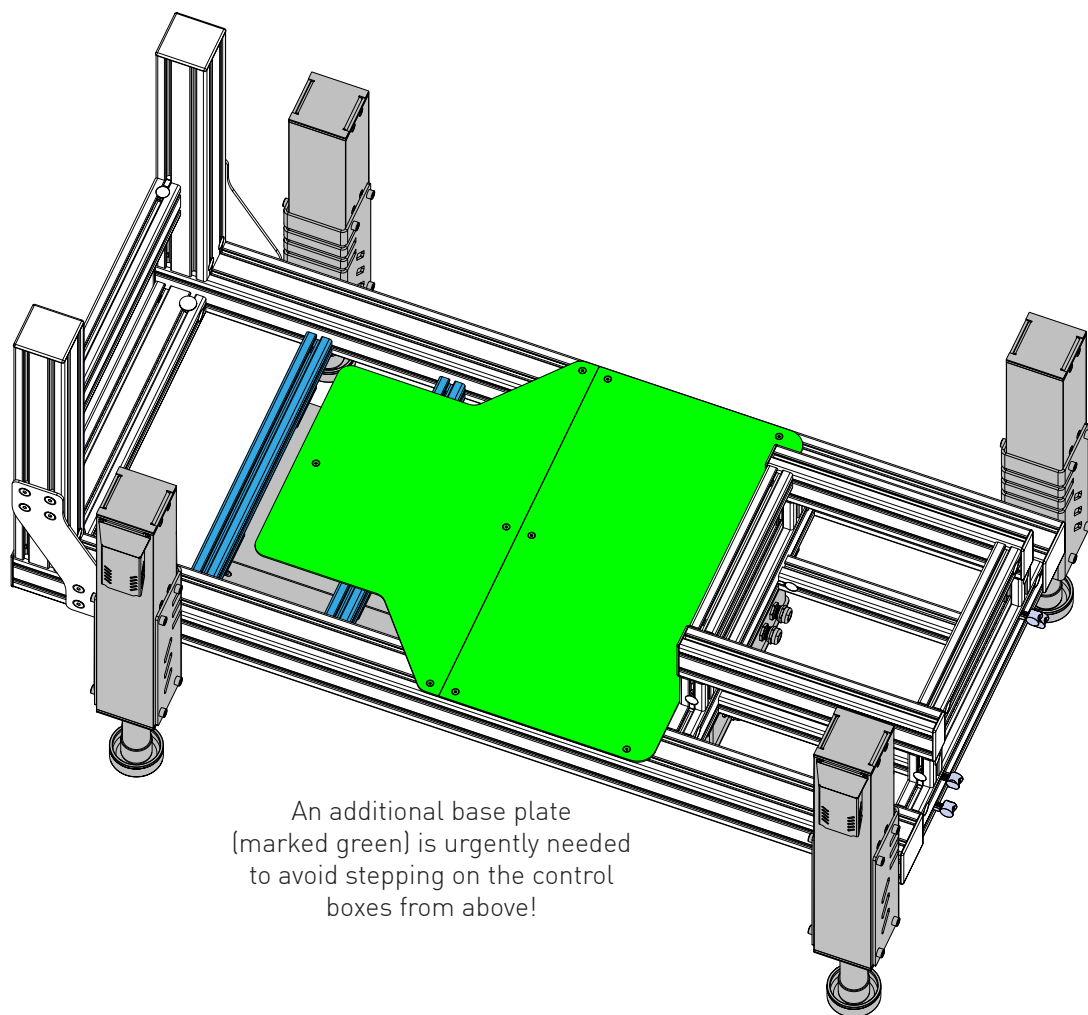
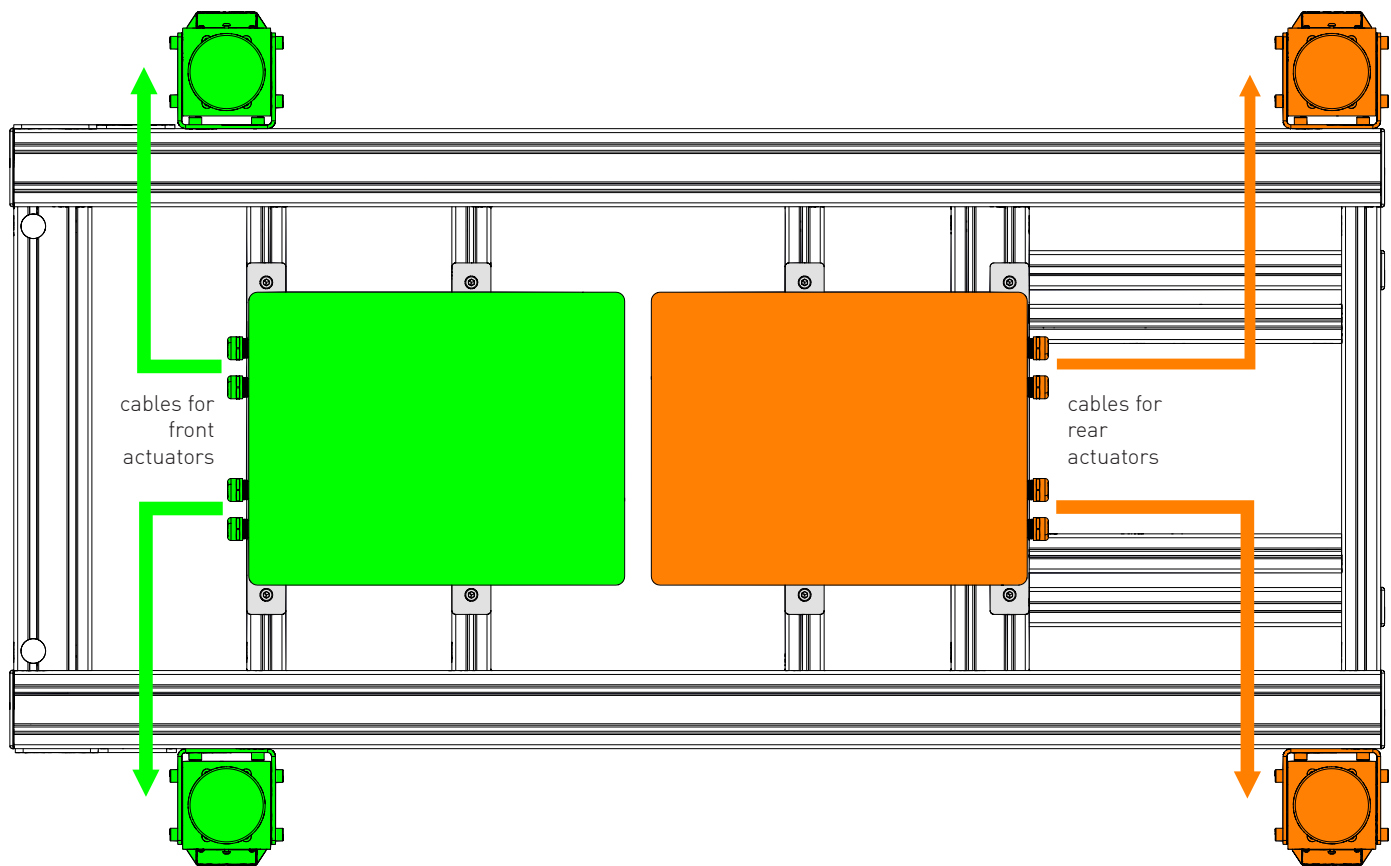

An additional base plate
(marked green) is urgently needed
to avoid stepping on the control
boxes from above!



15-01-2024