

**MTS  
YOKE**

Instruction Manual  
Bedienungsanleitung  
Mode d'emploi

# PARTS

[dimensions in mm / different scales]  
No extra or spare parts listed!

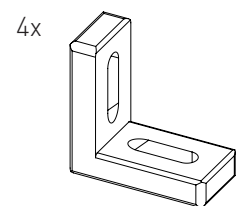
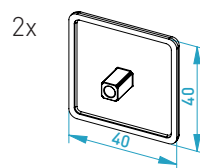
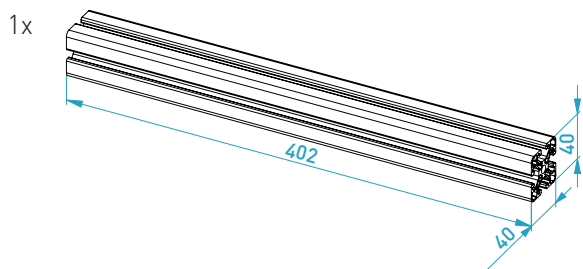
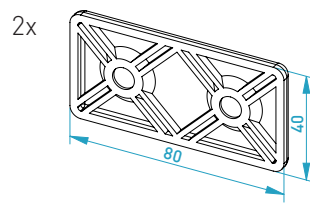
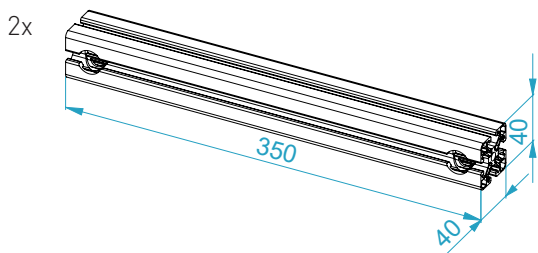
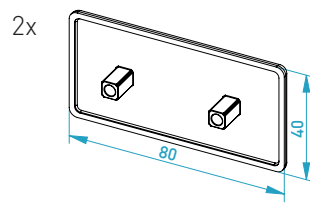
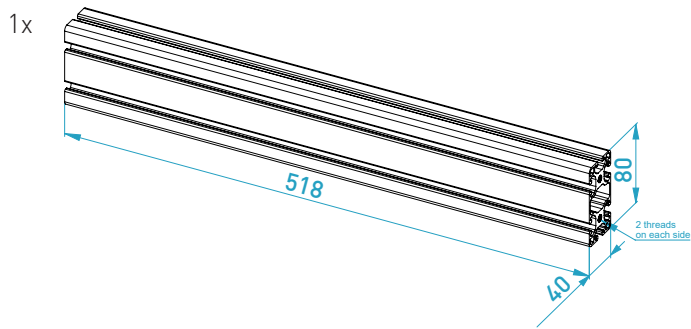
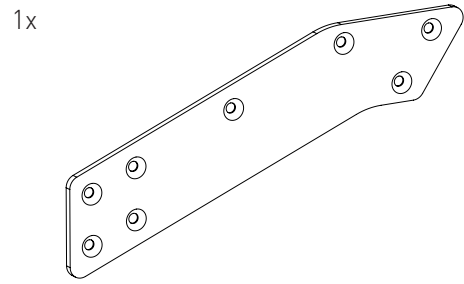
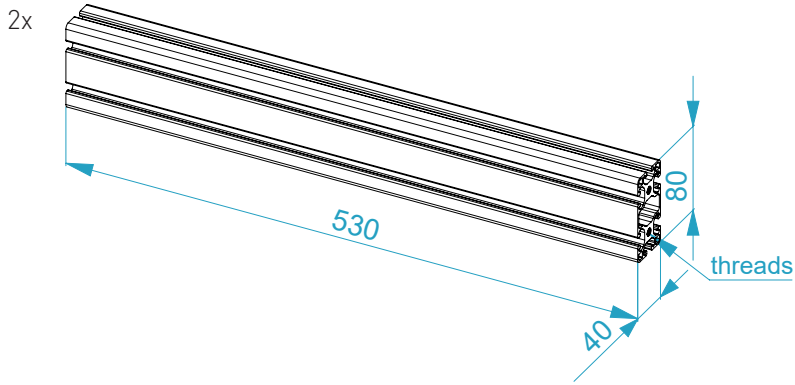
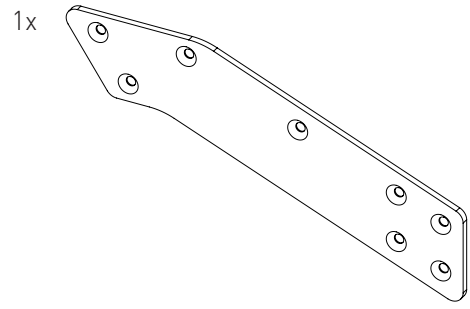
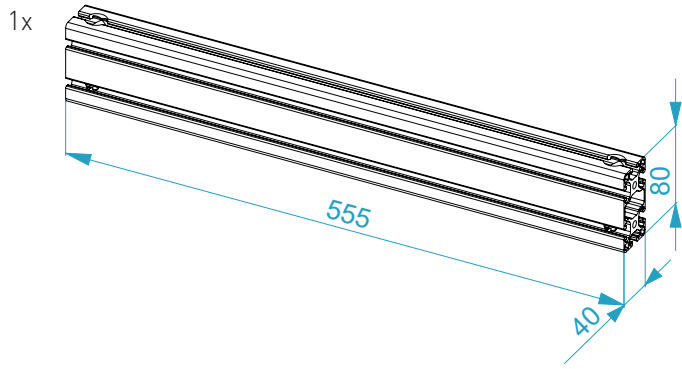

## BAG 1

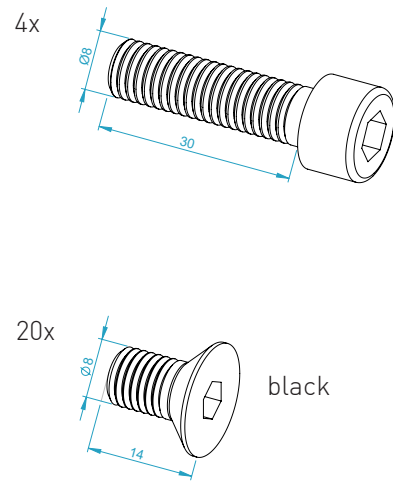
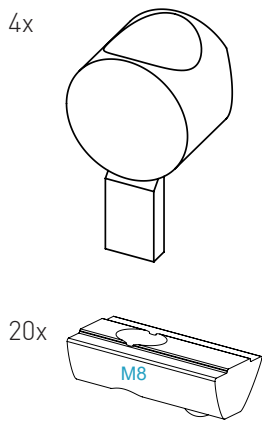

## BAG 2

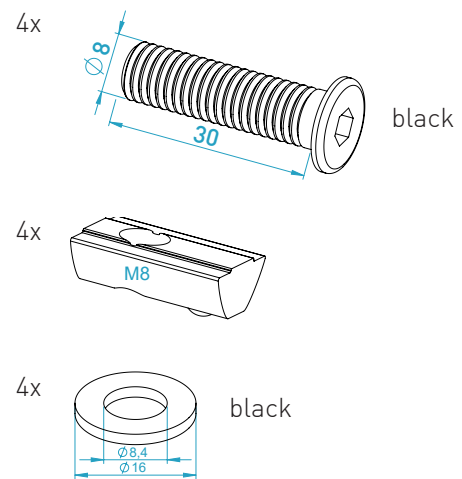
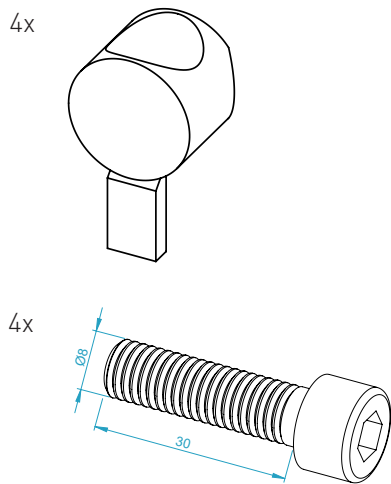

## BAG 3 with parts for yoke assembly

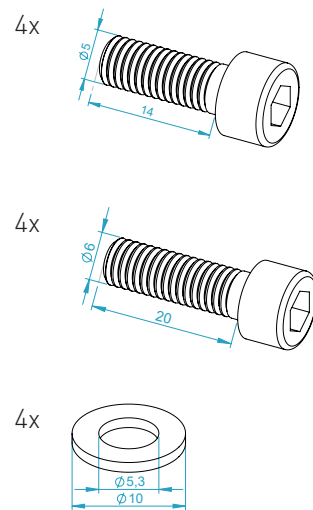
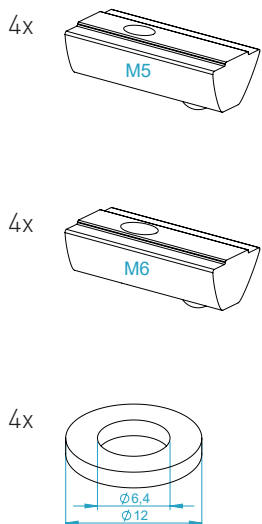

# PRE-ASSEMBLED

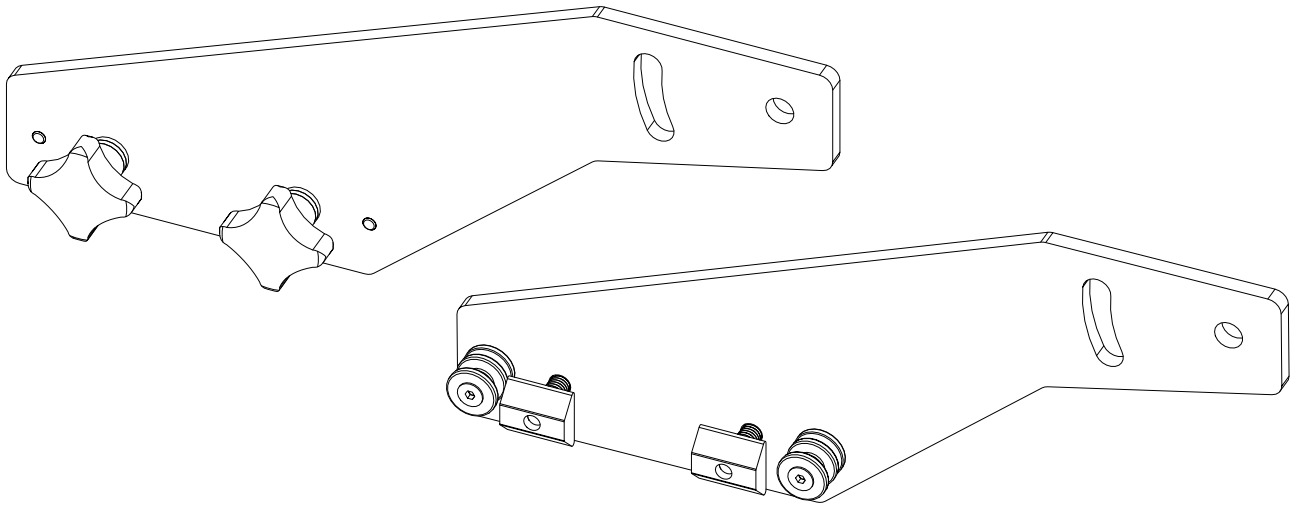

with this parts:

2x

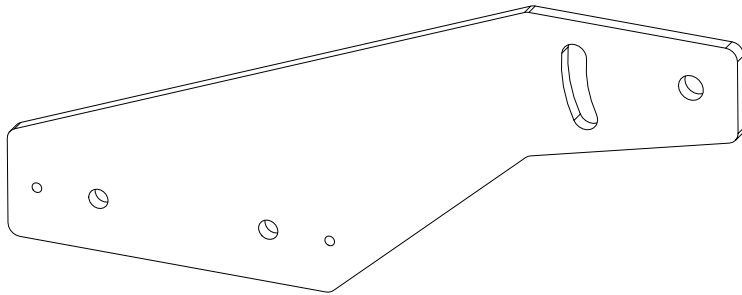

4x

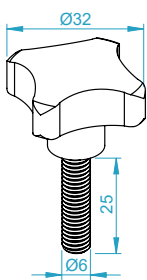

8x

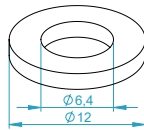

4x

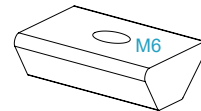

4x

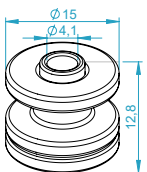

4x

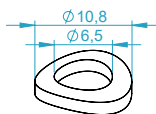

4x

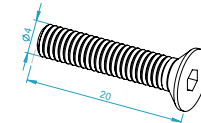

# ASSEMBLY

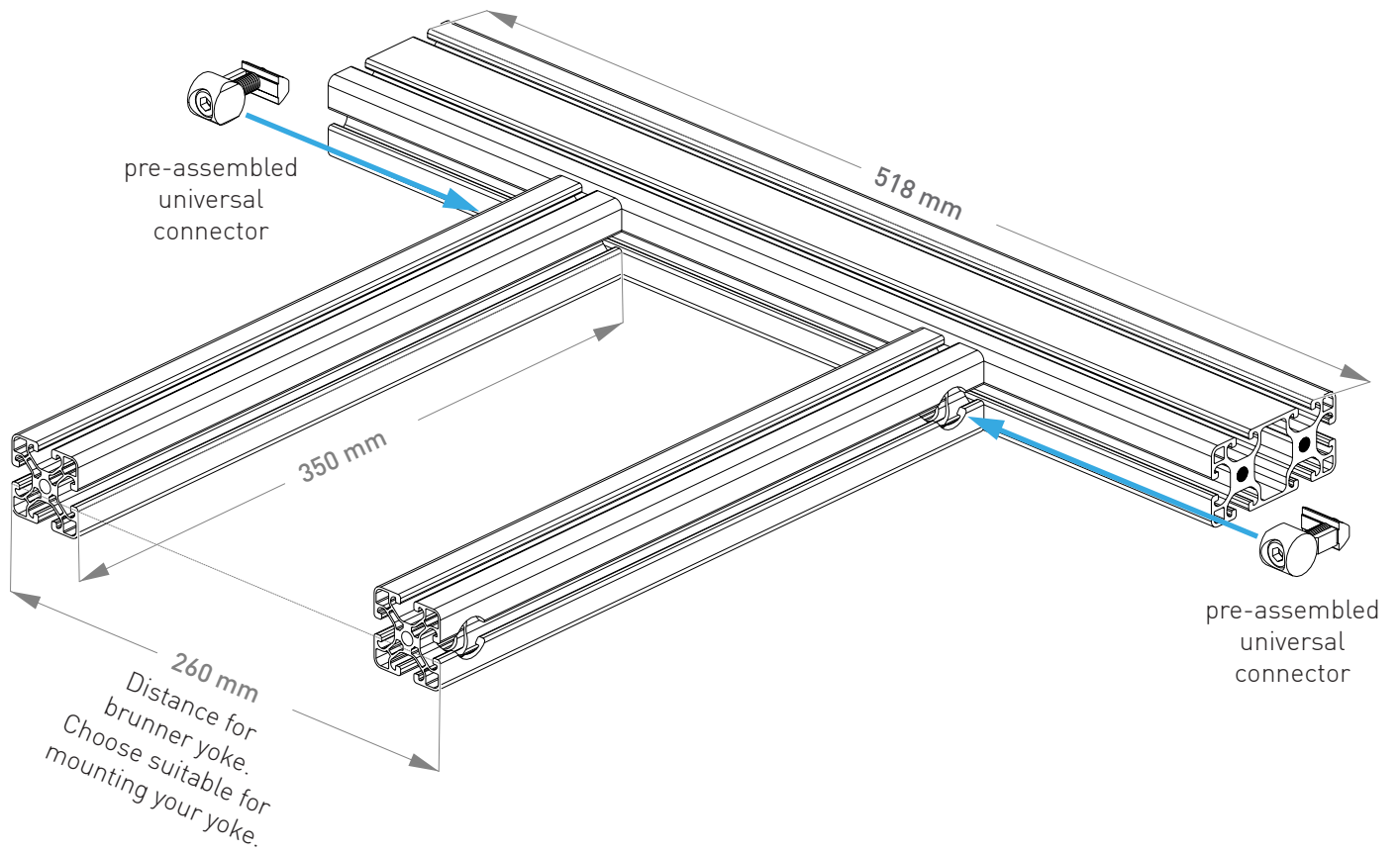
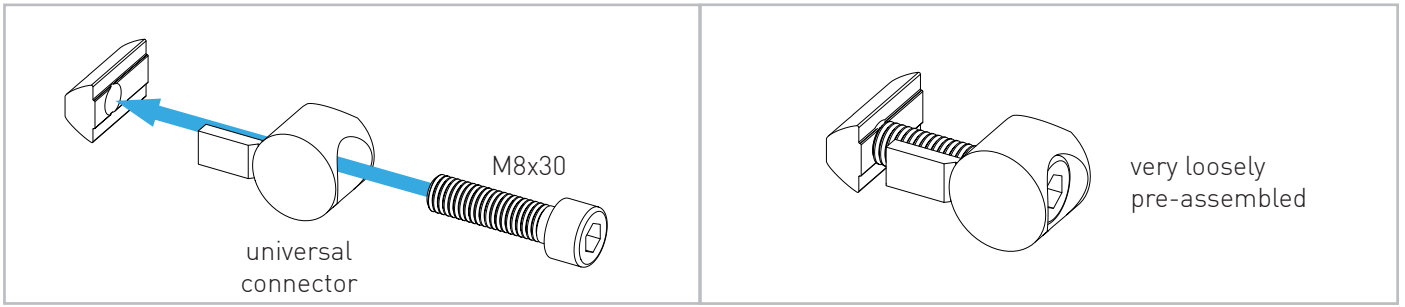

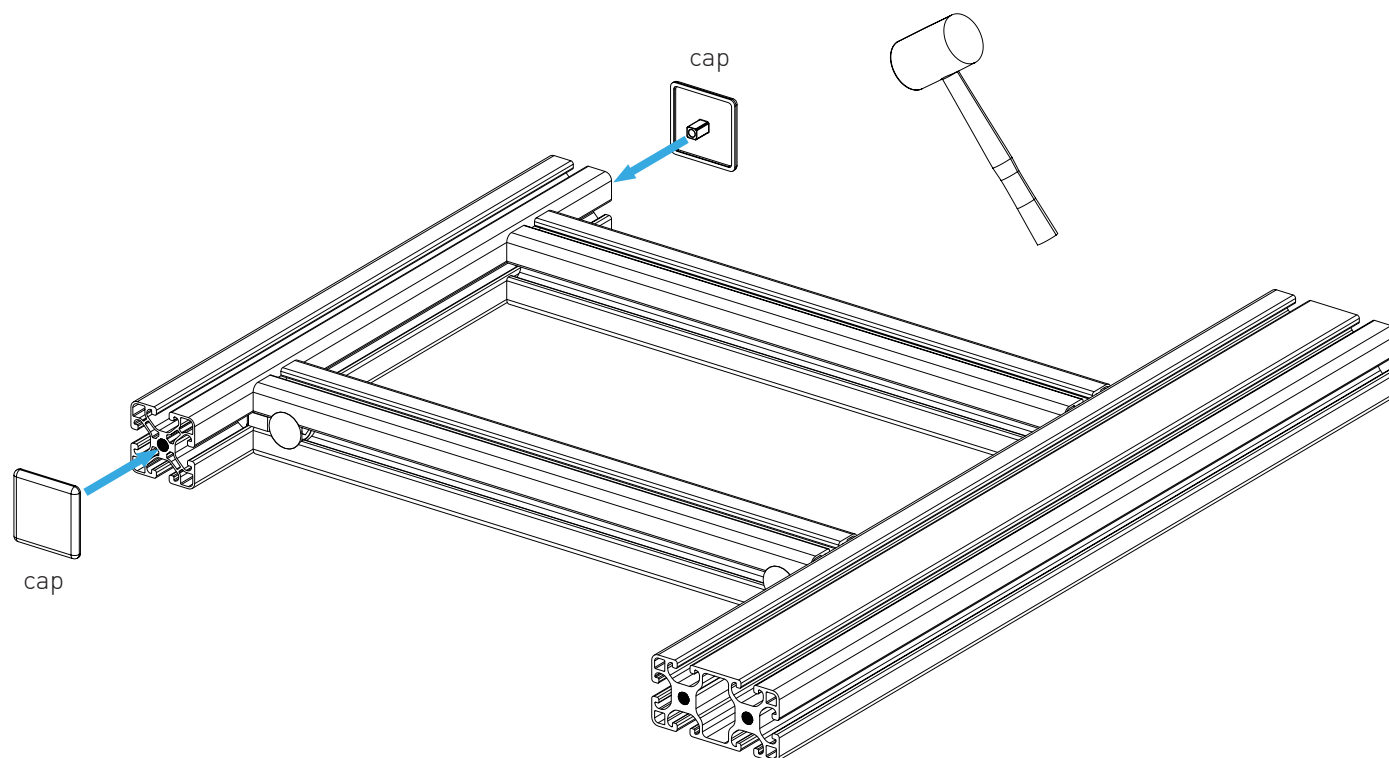
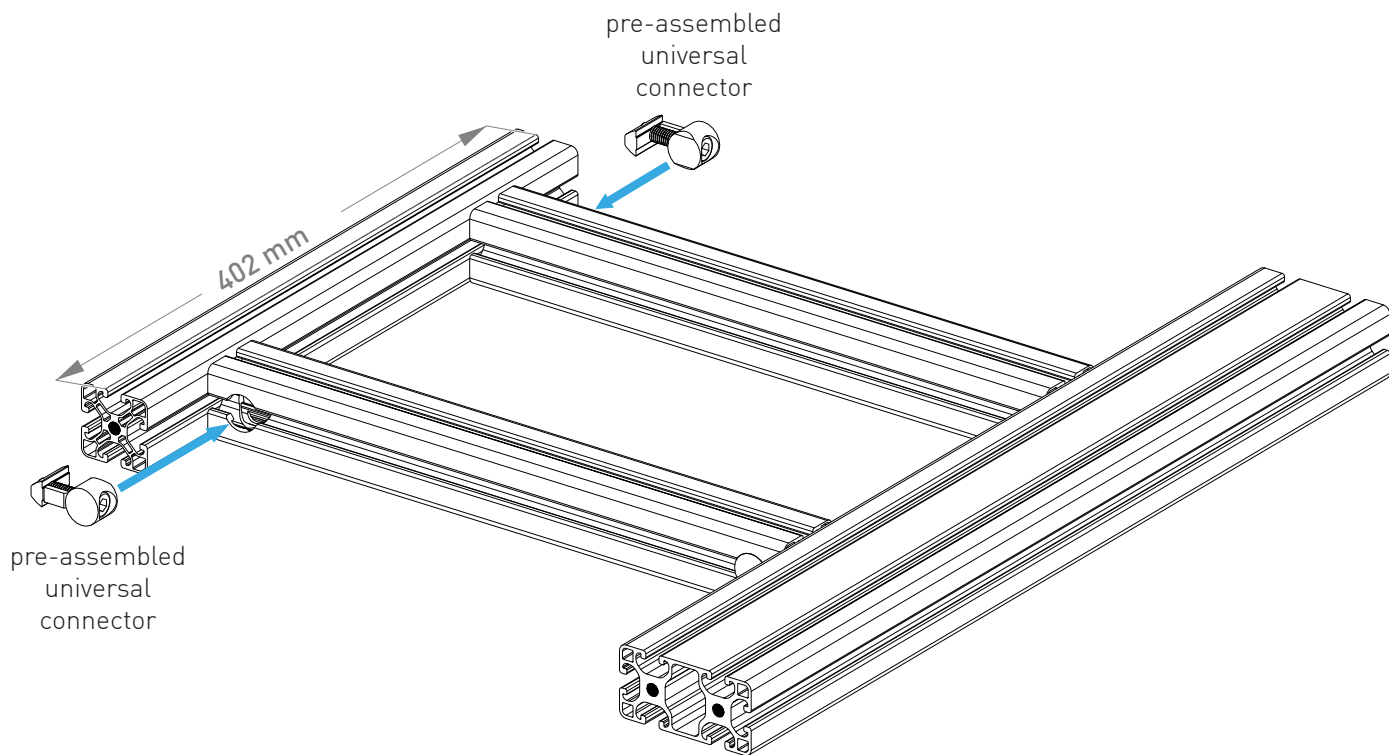

# USUALLY PRE-ASSEMBLED

2x

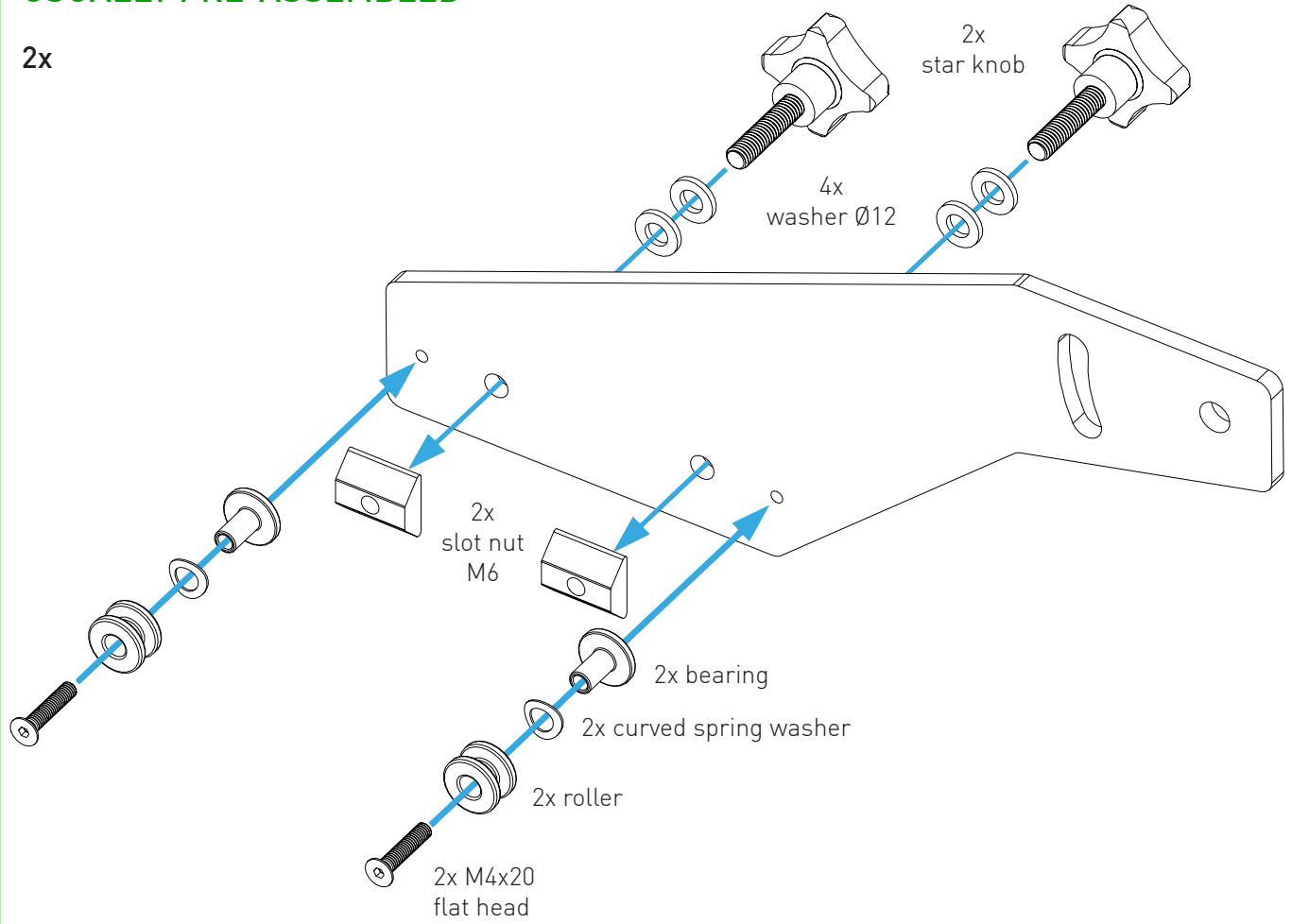

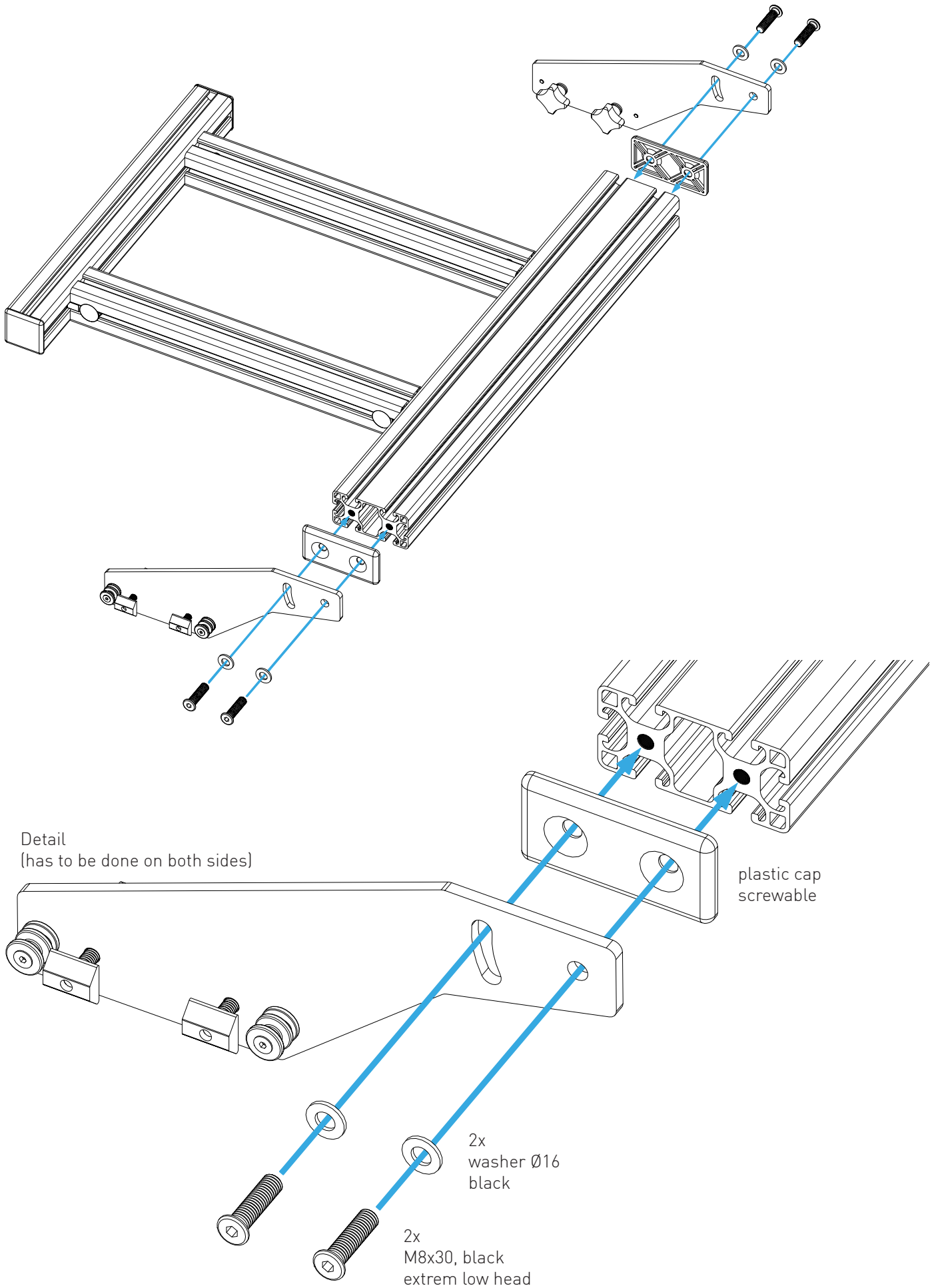



Use a plan surface  
for assembly.

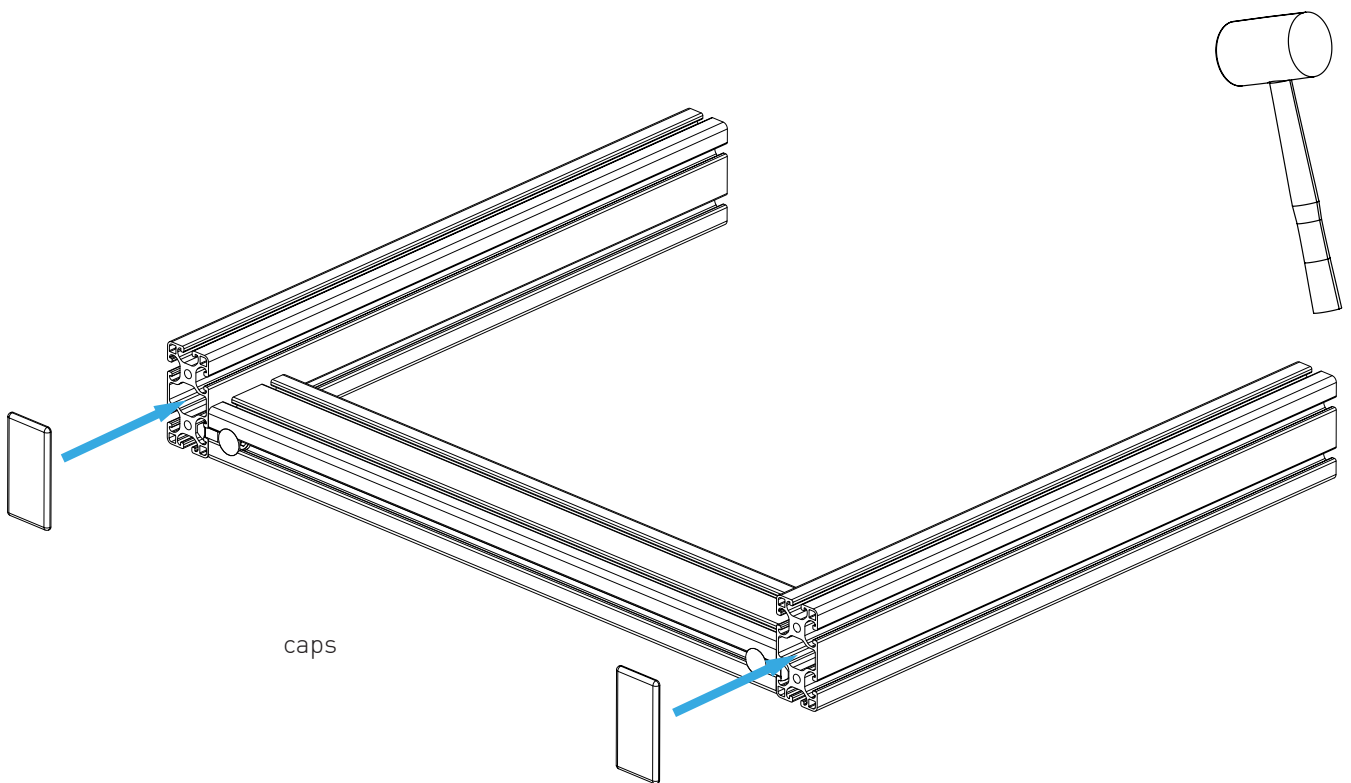
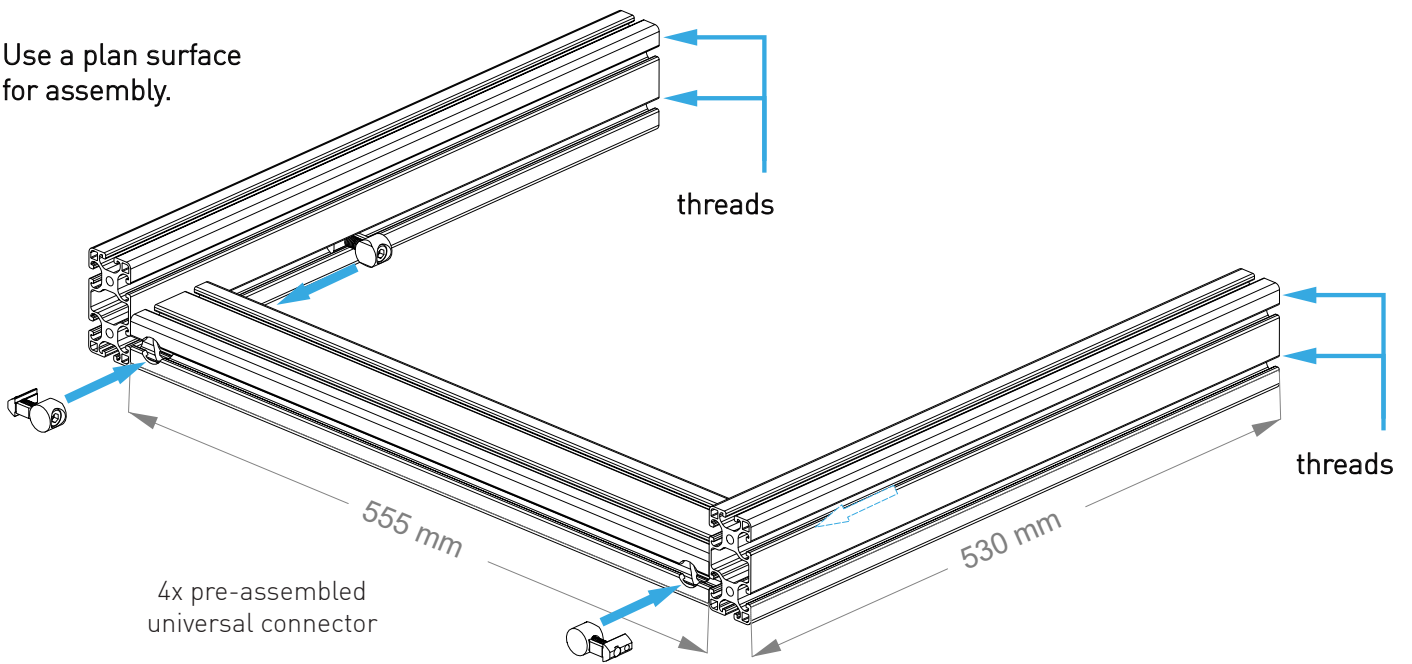

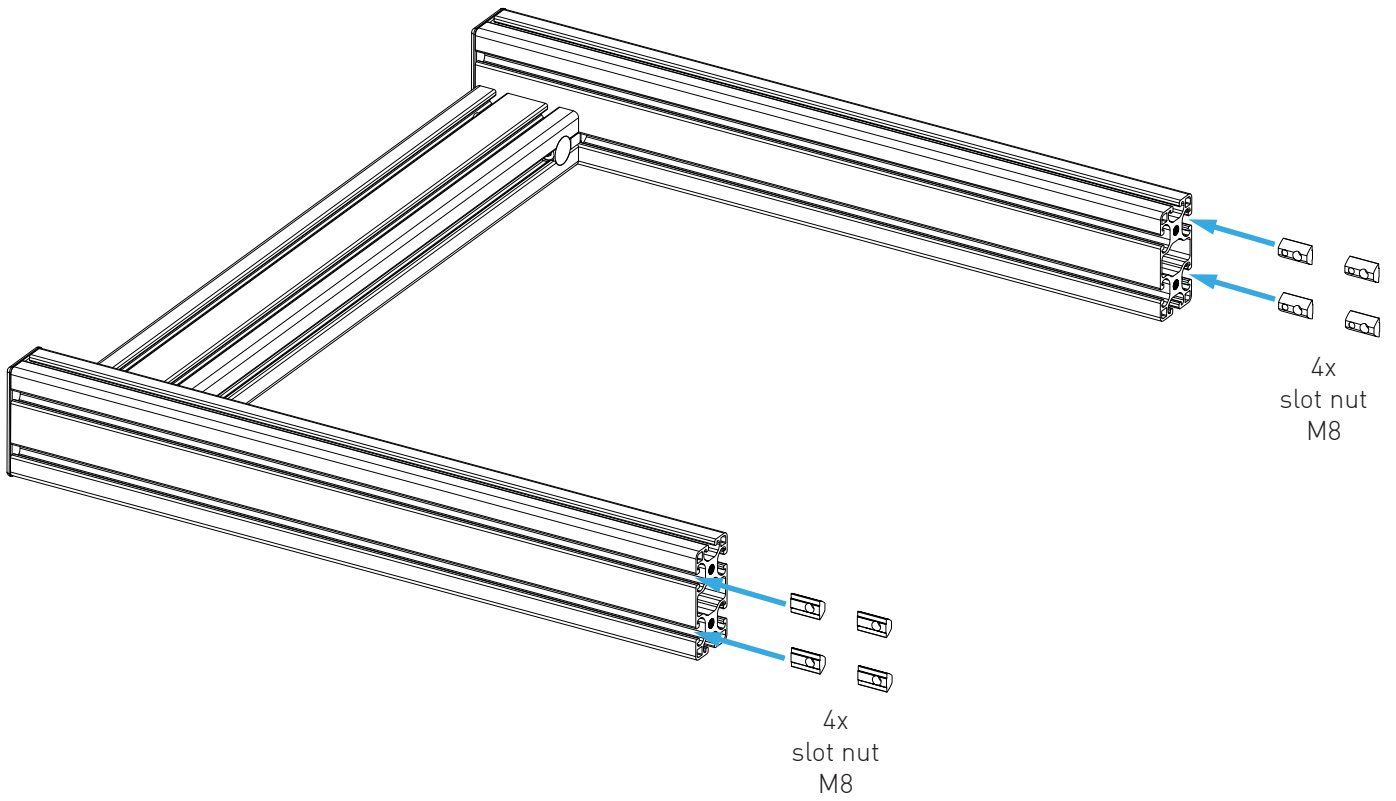

on both sides

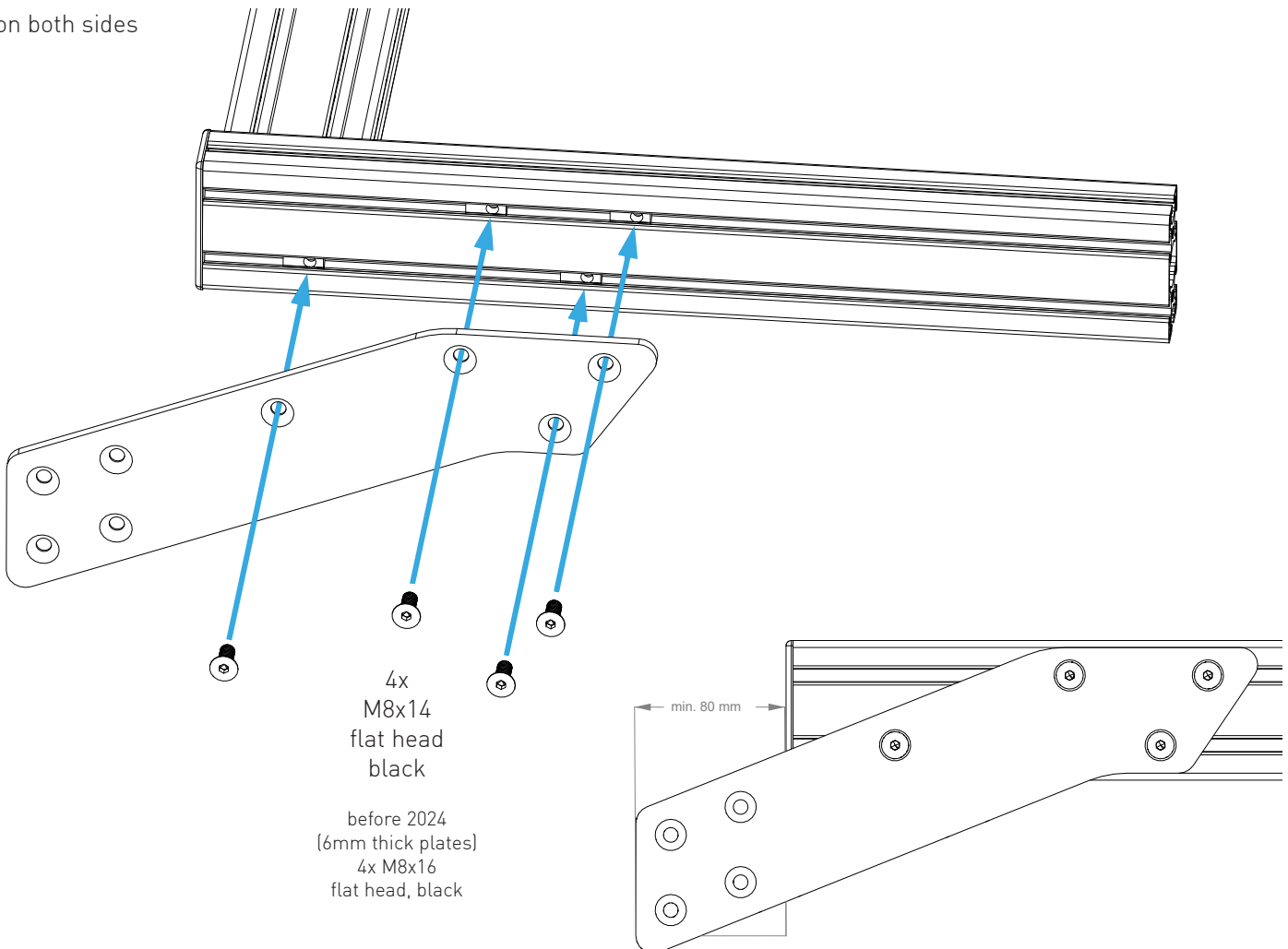

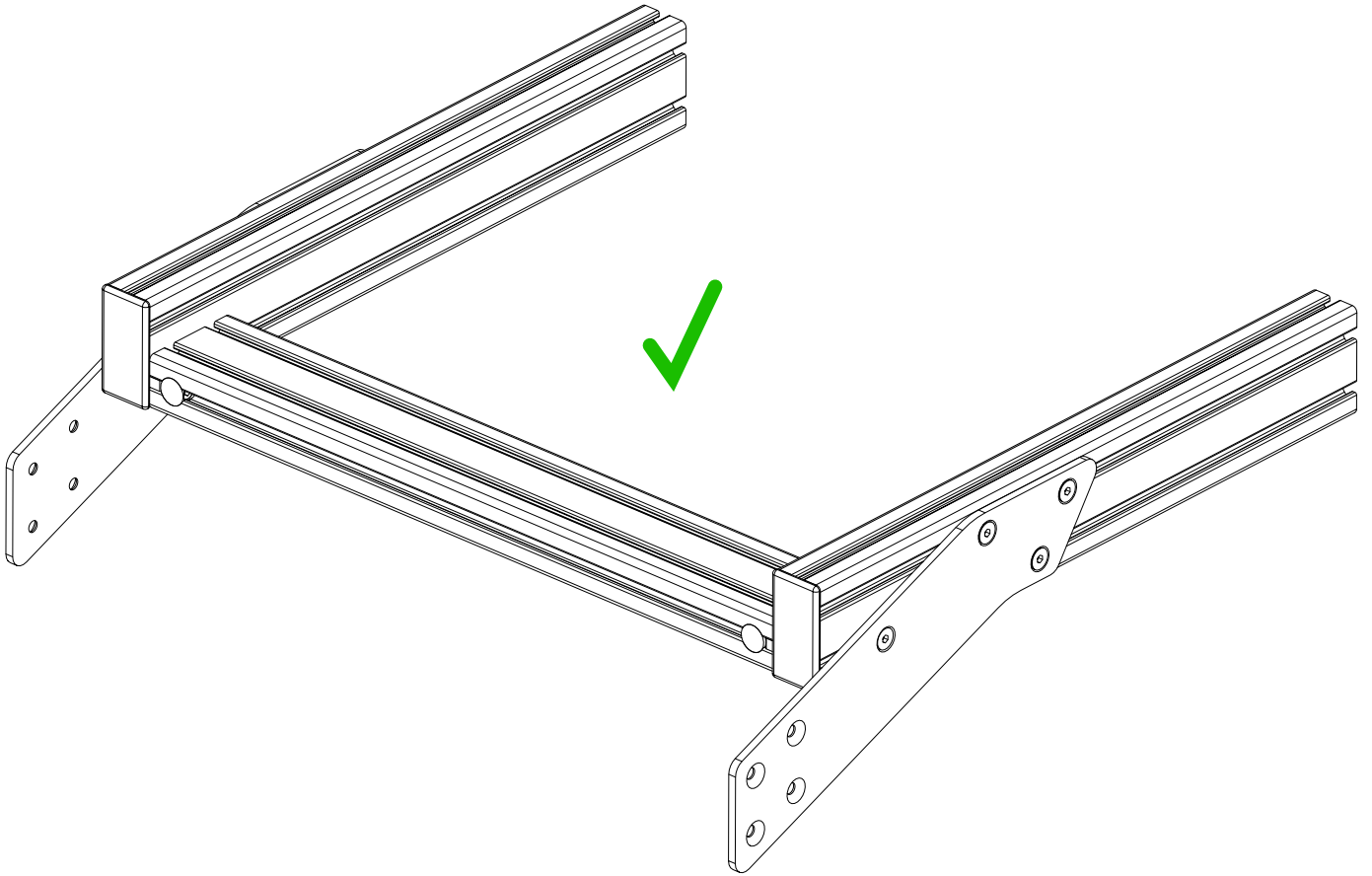

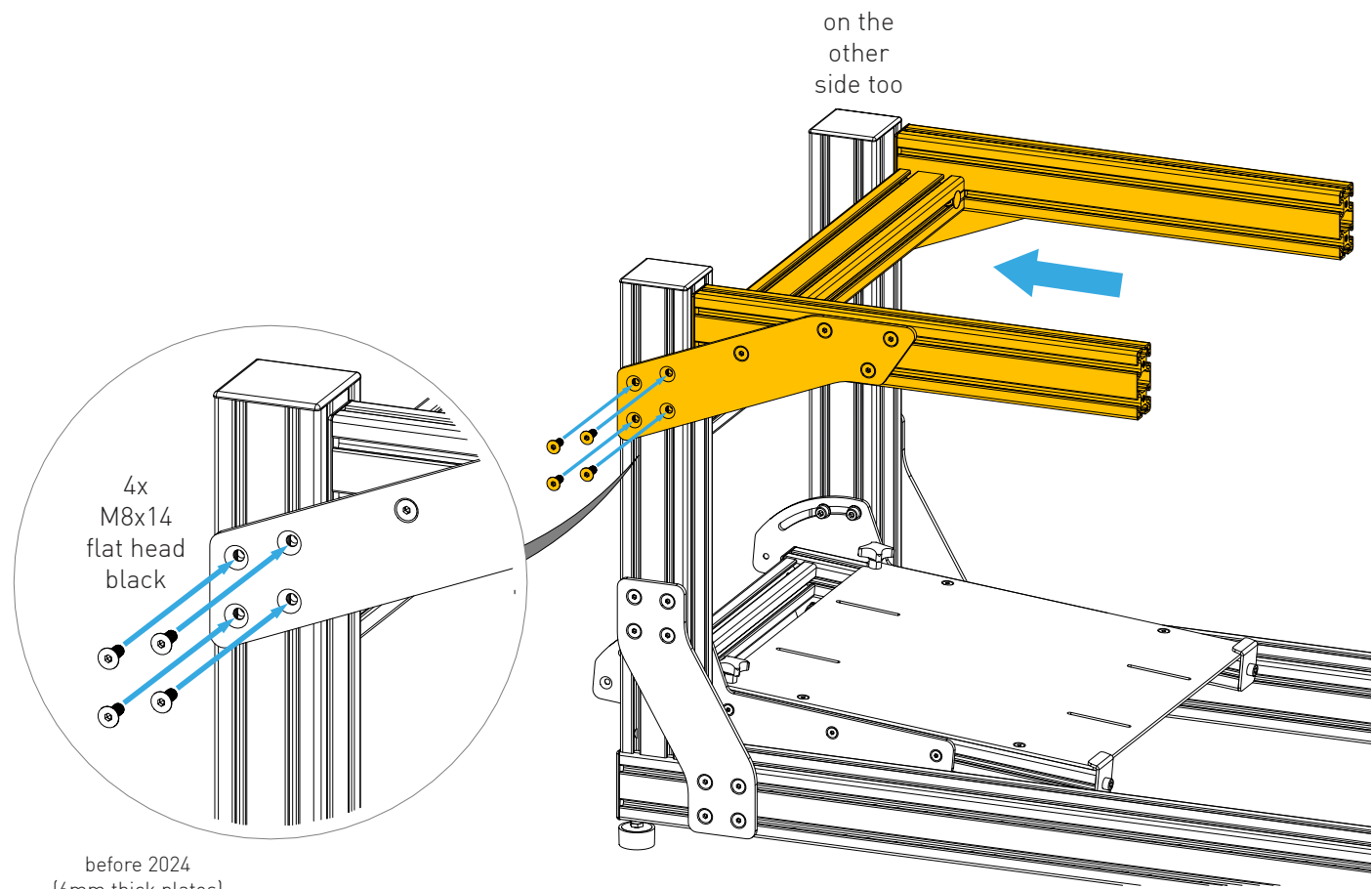
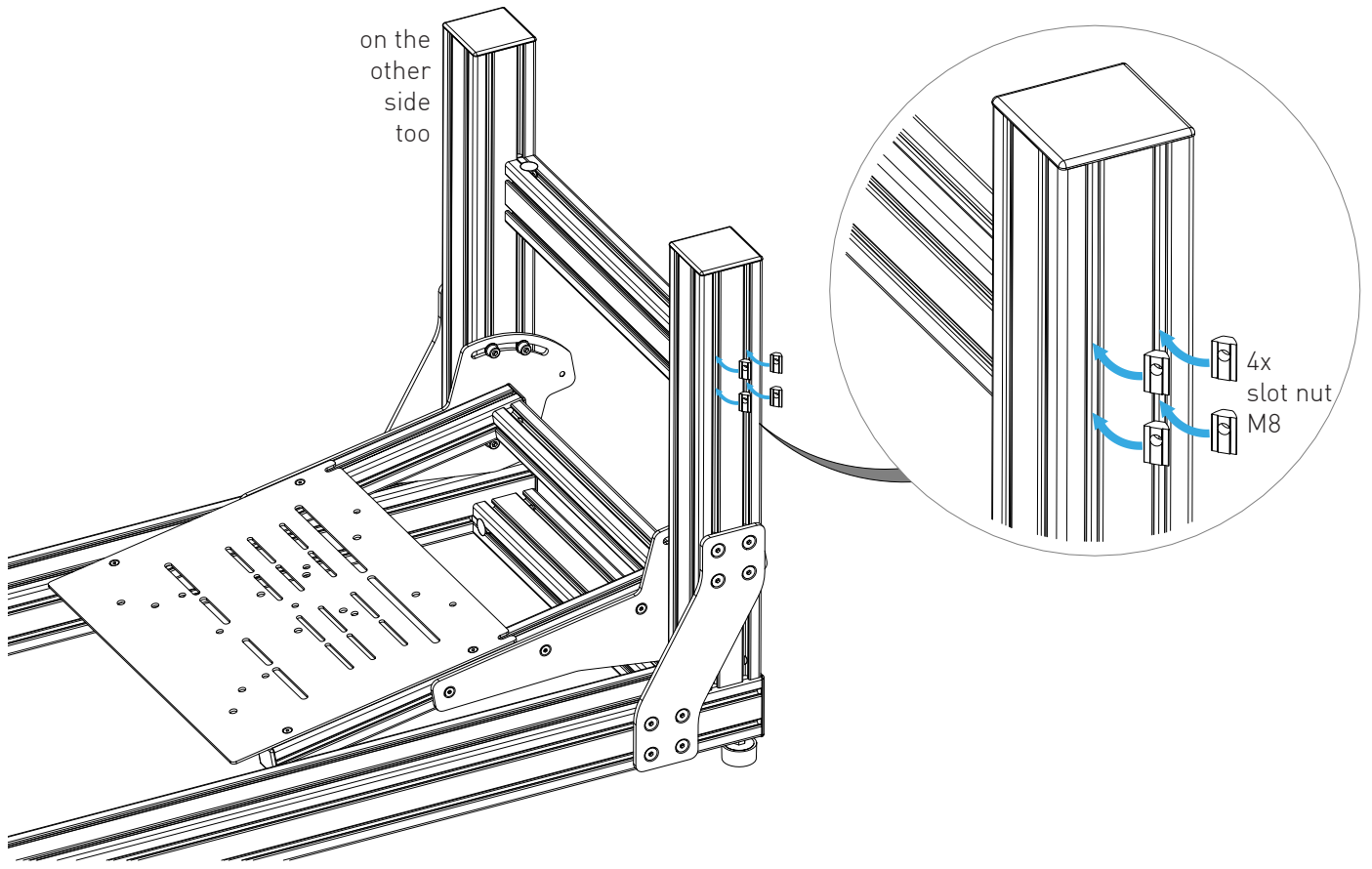

before 2024  
 (6mm thick plates)  
 4x M8x16  
 flat head, black

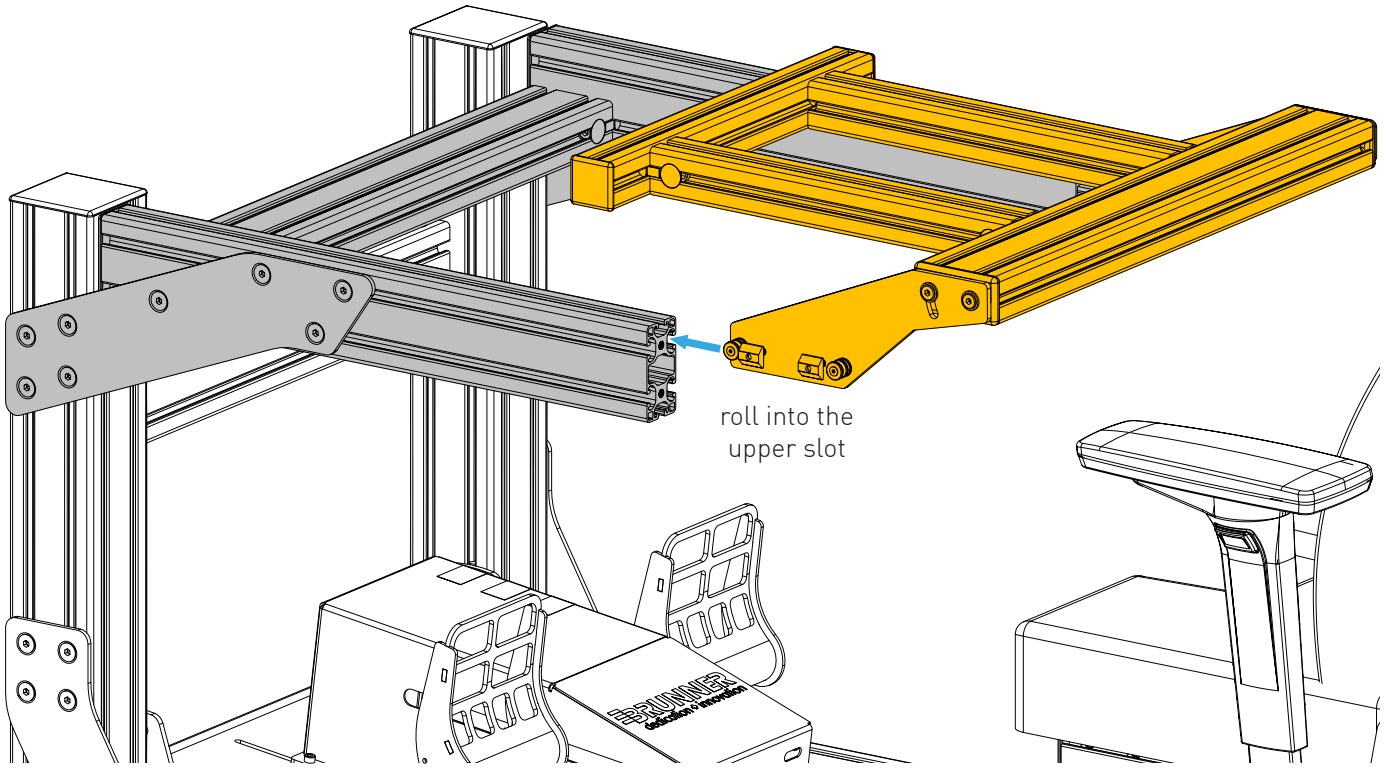

detail views

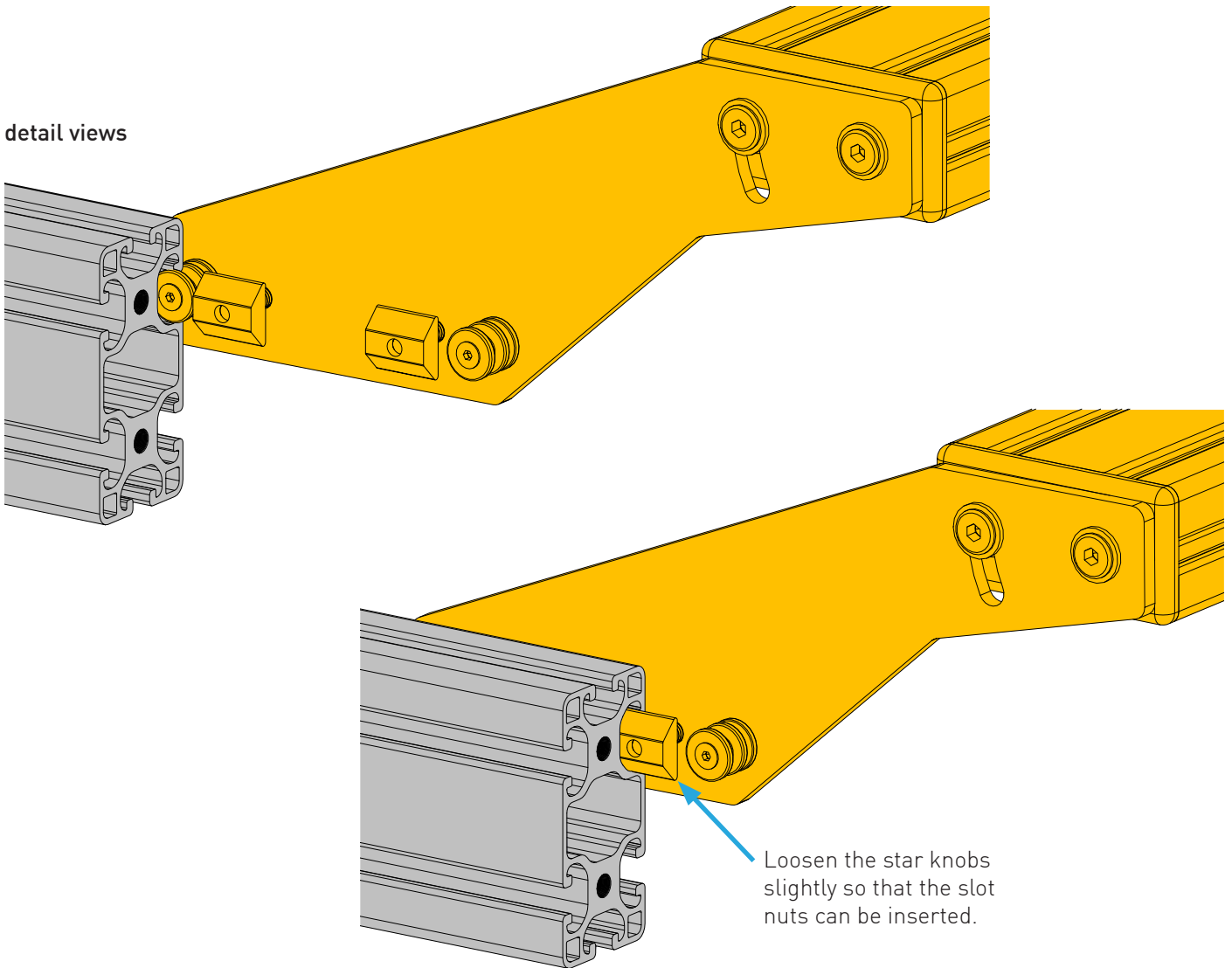

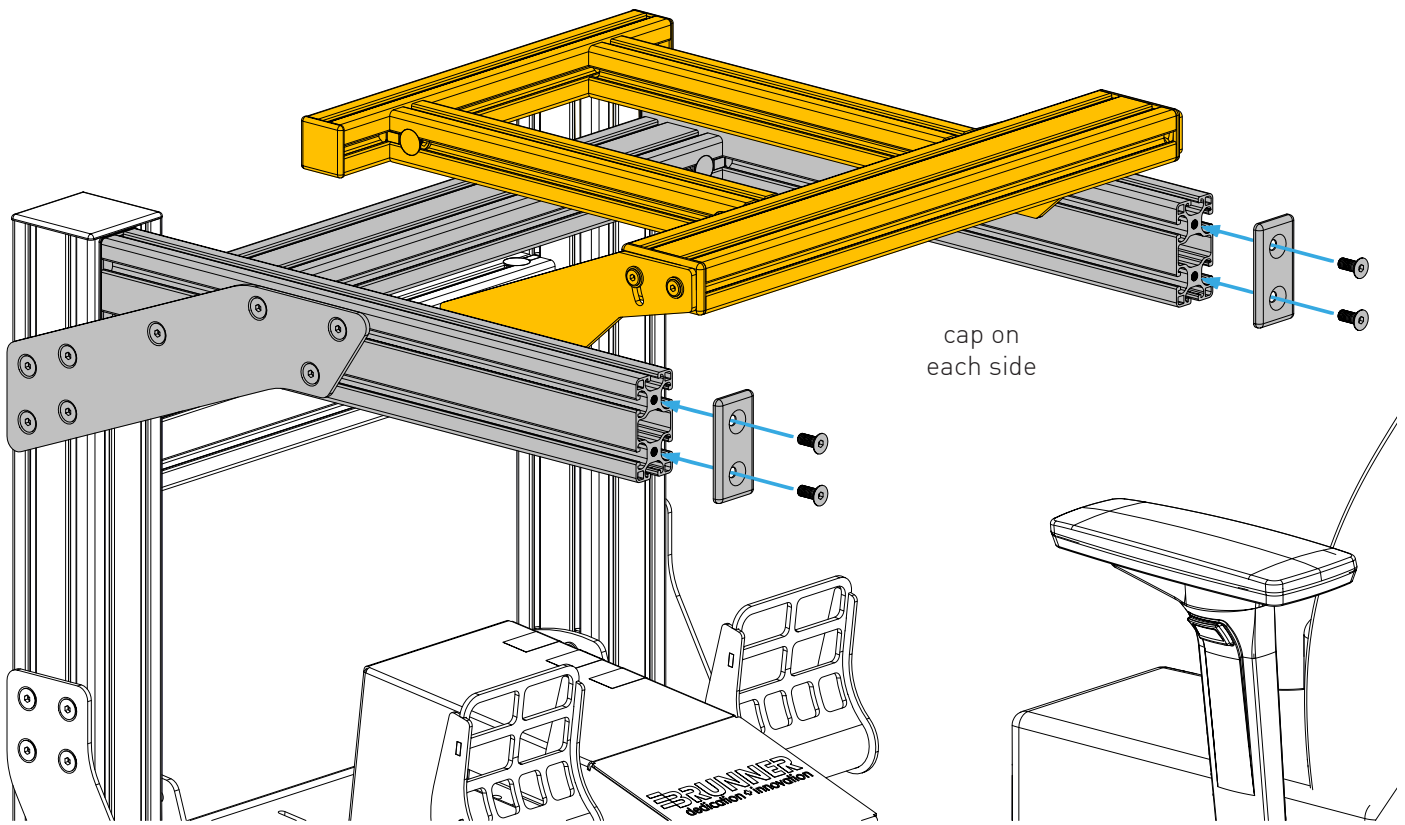

detail

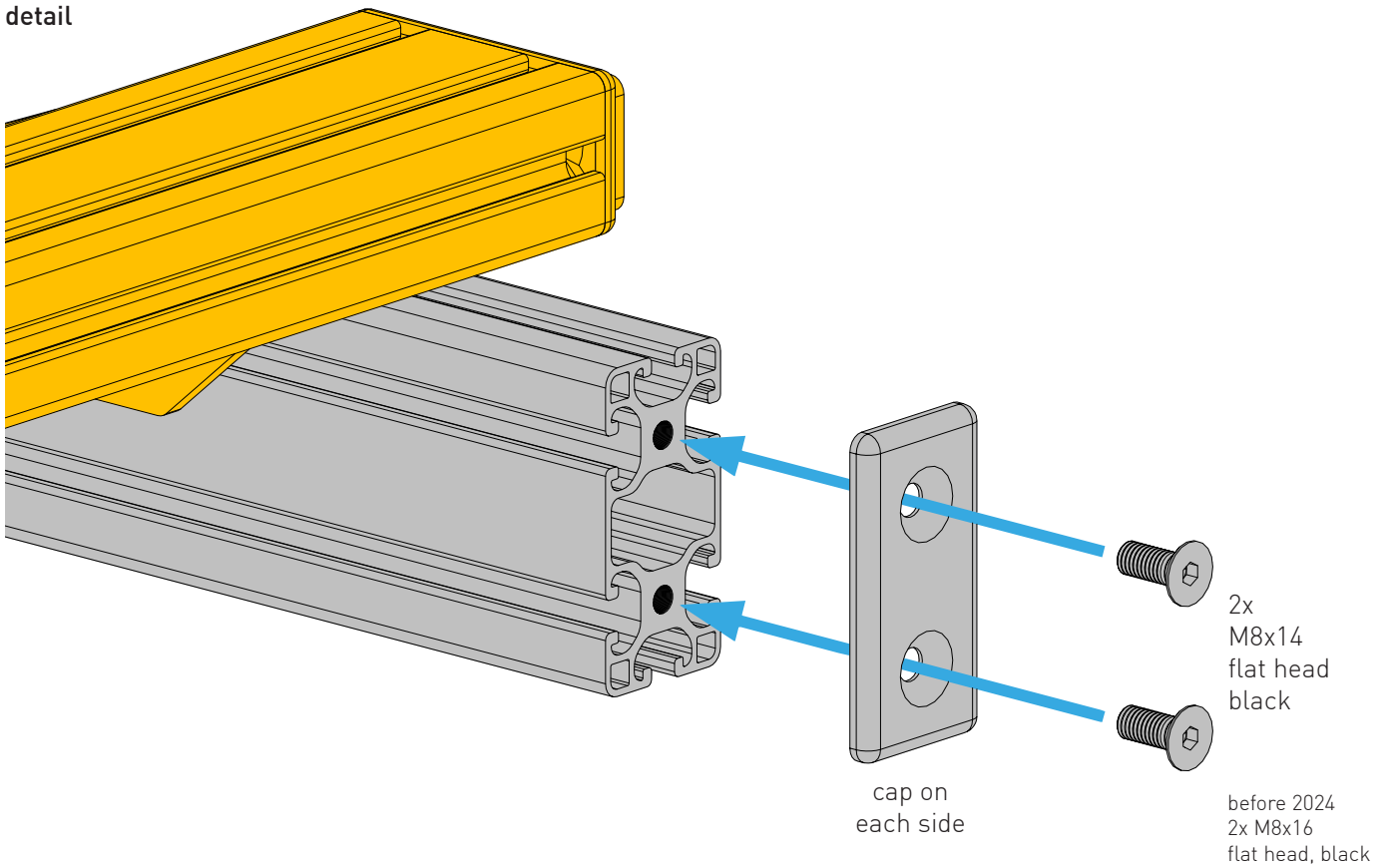

# ASSEMBLING A BRUNNER YOKE

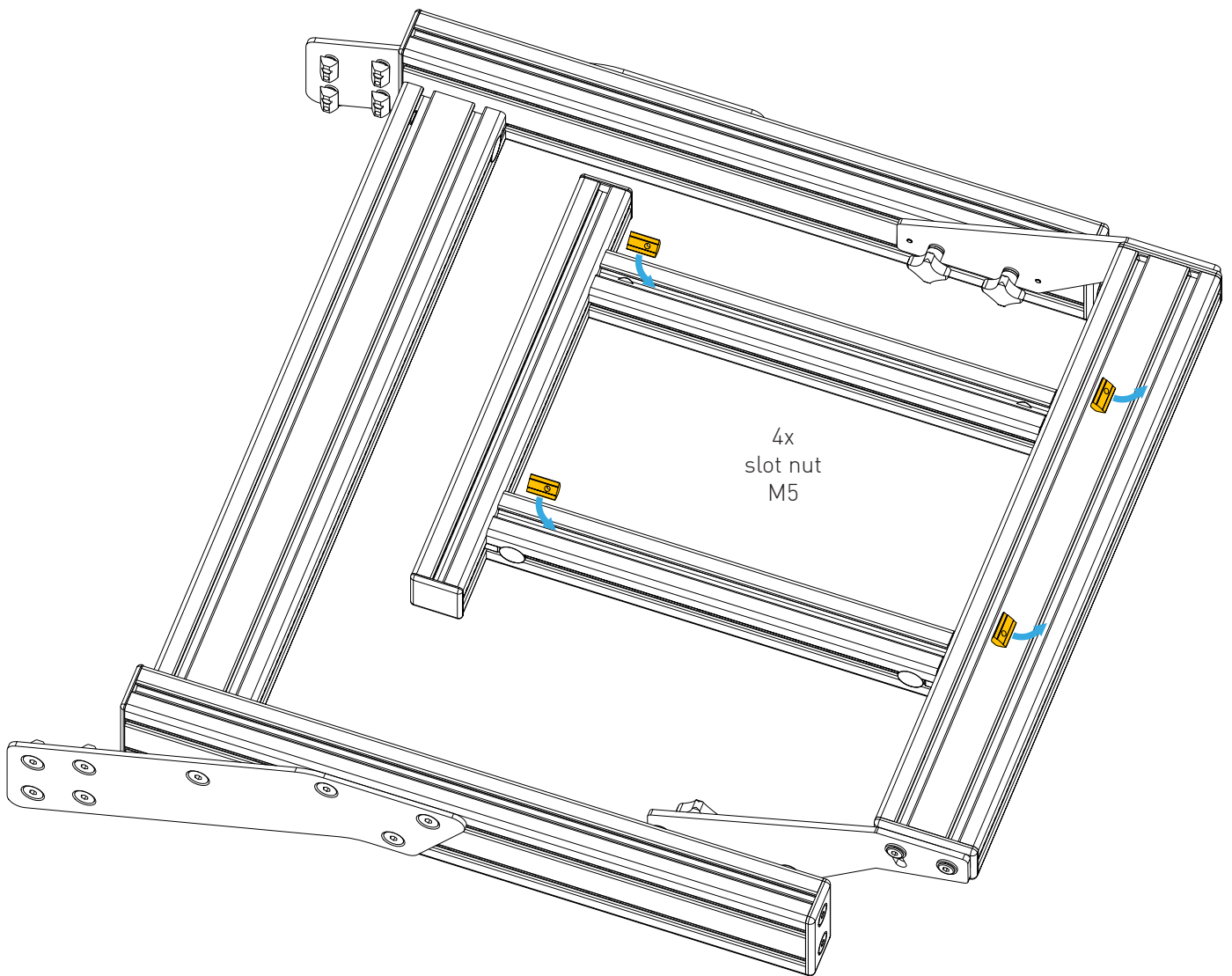

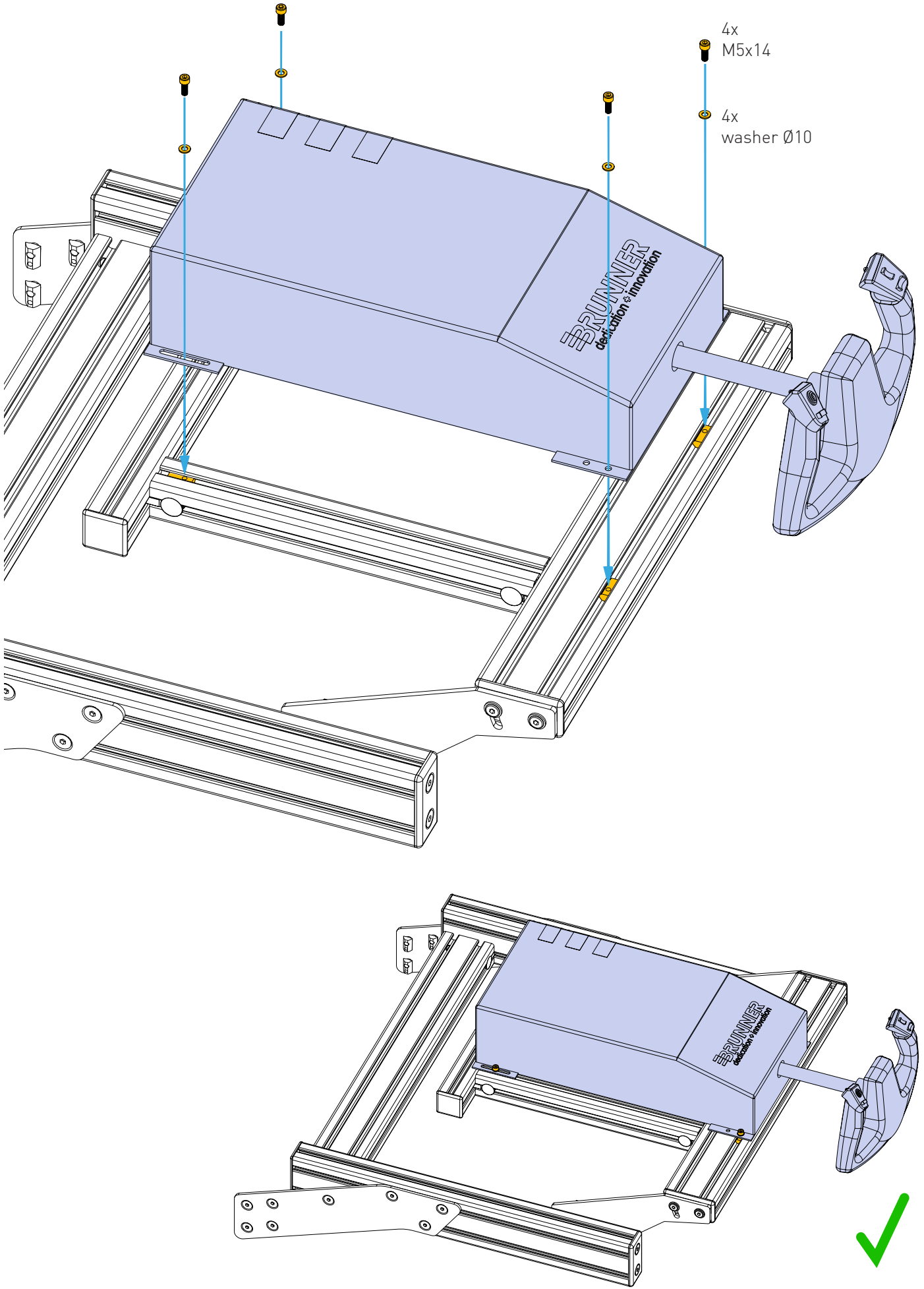



# UNIVERSAL ASSEMBLING WITH BRACKETS

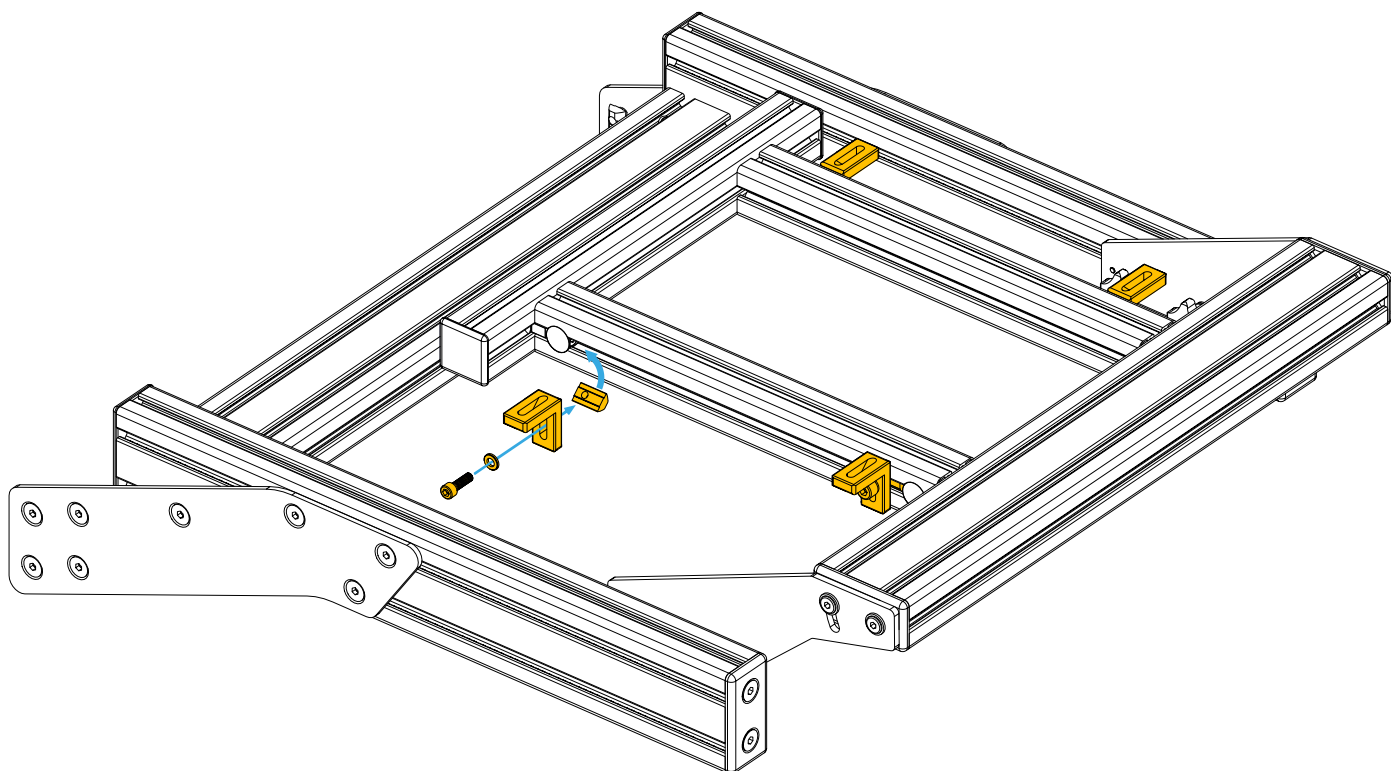

detail view

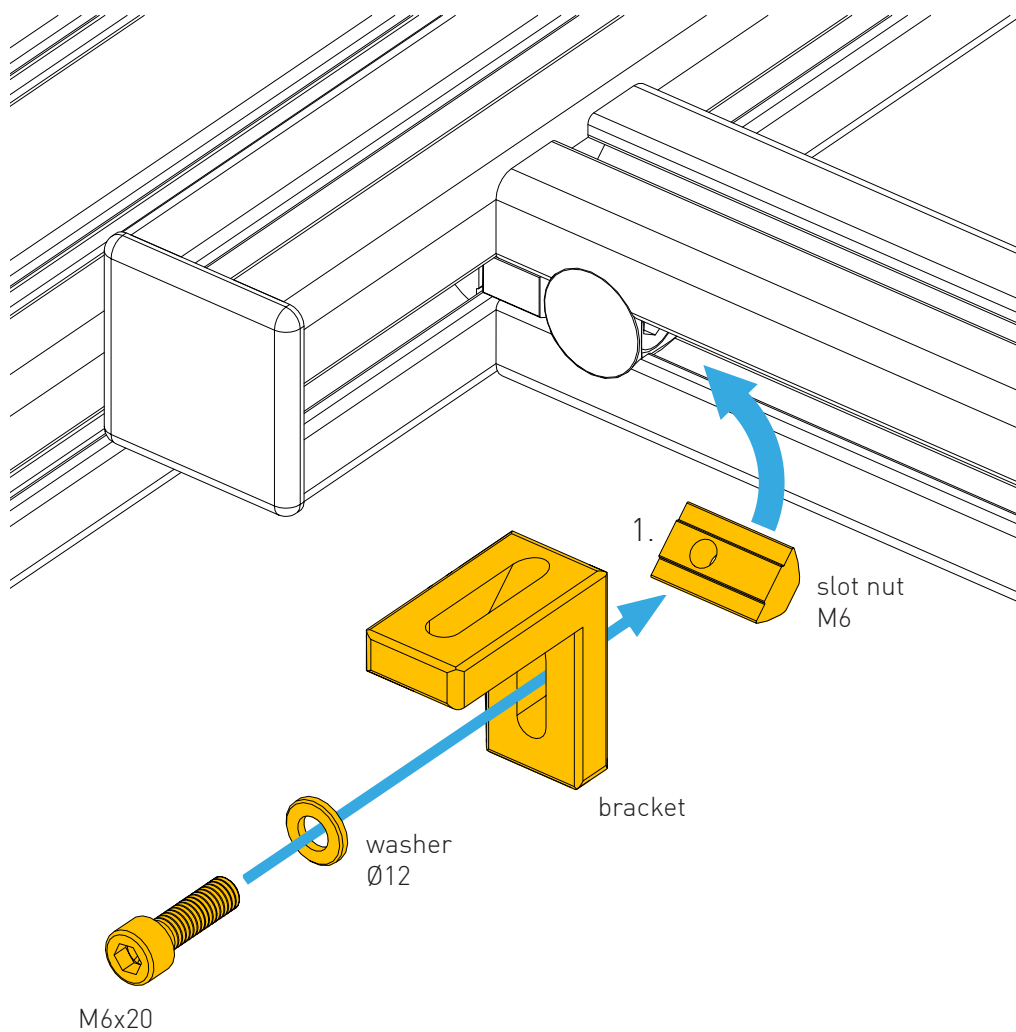

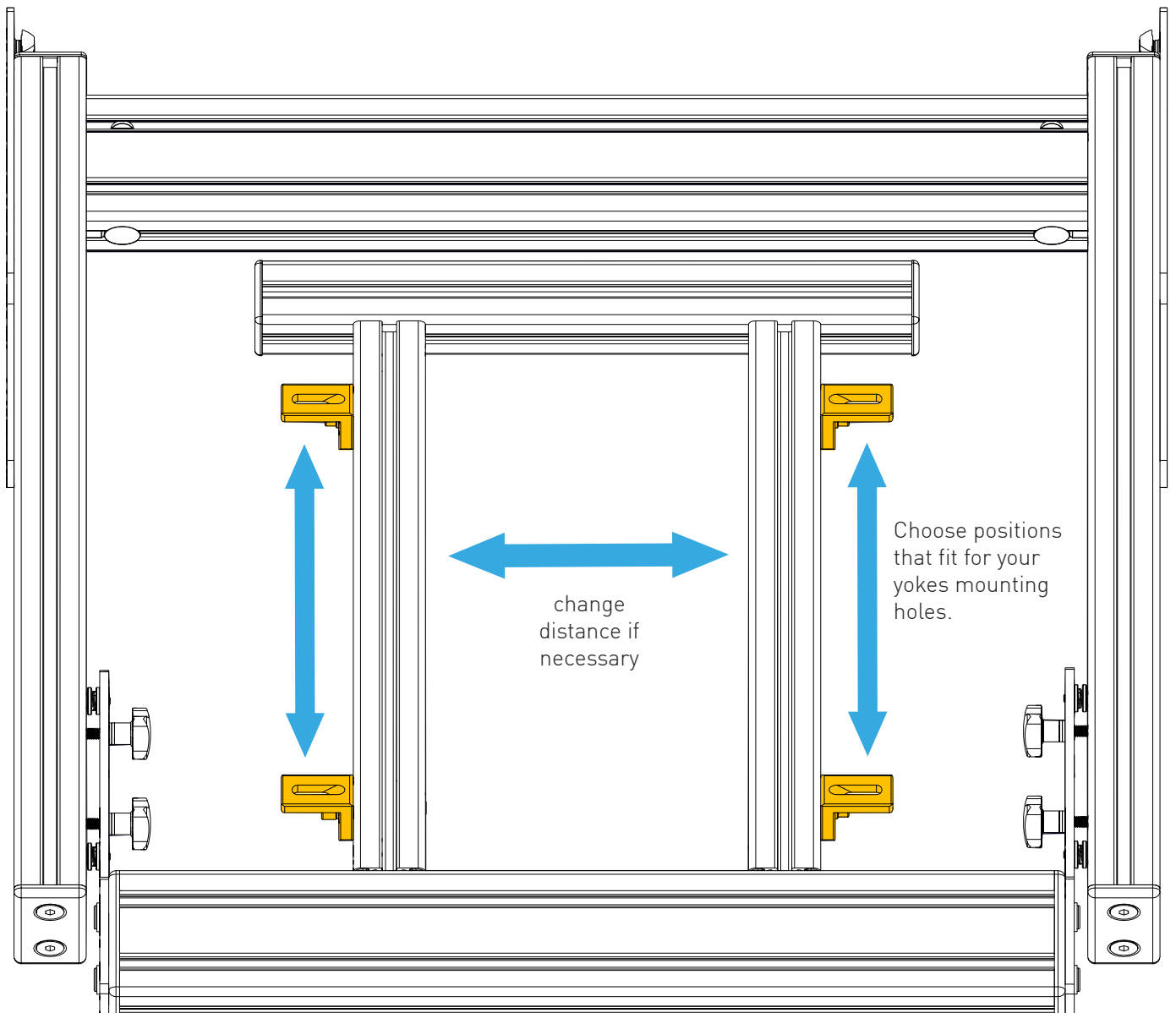

Alternative positions for the brackets

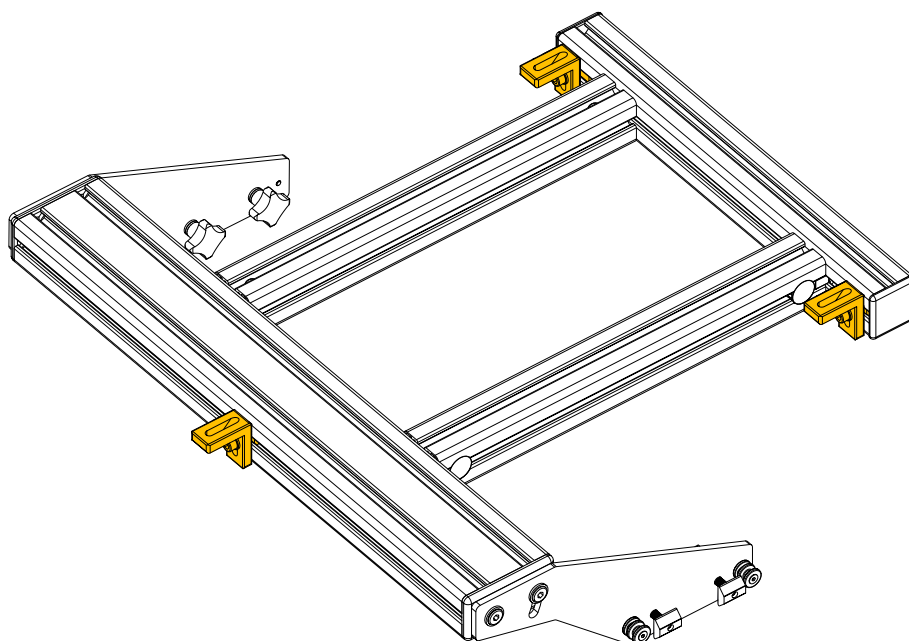
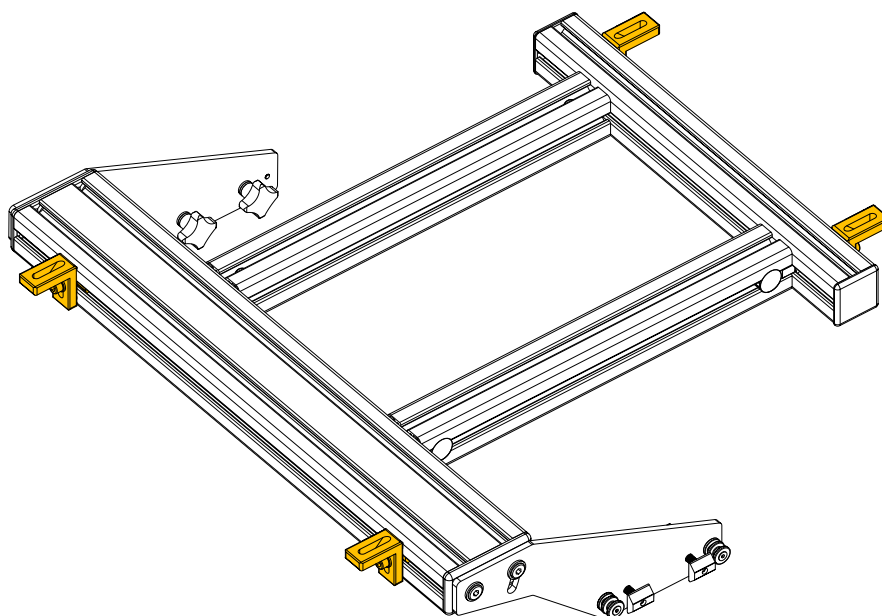
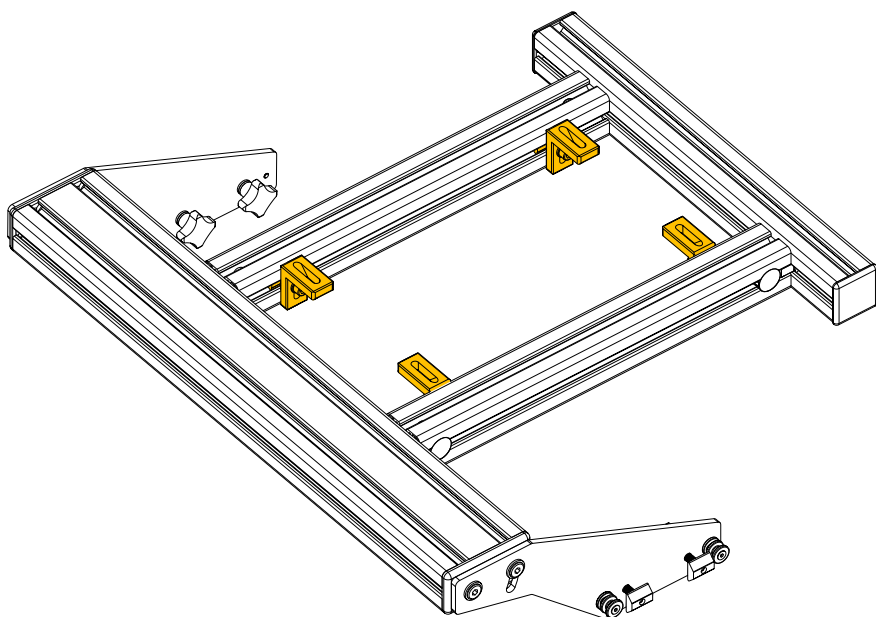

# OPERATION

